

CHEMICAL

PETROCHEMICAL

REFRIGERATION

ENERGY

SERVICE



Convincing worldwide:  
HERMETIC pumps  
in the refrigeration industry

 **LEDERLE**  
*Hermetic*

RESPONSIBILITY  
FOR THE  
ENVIRONMENT



*Attitudes towards environmental awareness as well as social responsibility have steadily grown in the refrigeration industry. As an essential feature refrigeration plants must operate in a hermetically sealed way and thus, the importance of tightness has become more and more important for engineering, ecological and economical reasons. Therefore, both safety in plants as well as environmental protection play an important role in business strategy. Not only ice-cream and frozen foods need to be cooled, but almost every food. Typical application ranges include rail vehicles, toboggan-runs, bob runs, breweries, etc. in which HERMETIC pumps have been successfully used for reliable cooling of plants and production processes. HERMETIC has been dedicated to the development and production of hermetically sealed pumps for a period of 50 years. HERMETIC pumps are designed for applications in the chemical and petrochemical industry, as well as for process technologies. The refrigeration industry also benefits from this experience made in these industries. There are more than 76.000 HERMETIC pumps installed in refrigeration plants worldwide.*

## HERMETIC – synonym for hermetically sealed pumps and reliability.

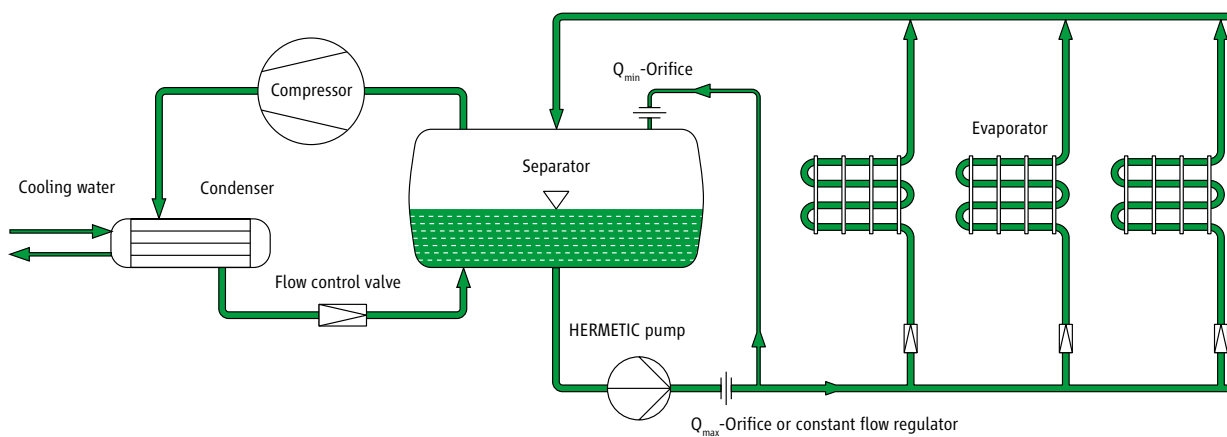

The figure shows the simplified scheme of a large refrigeration plant. The characteristic of this plant is that the refrigerant flows through a central fluid separator and is then conveyed to the evaporators. The resulting vapour and the surplus fluid return

back to the separator. Compressor, condenser and flow control are incorporated in a secondary circuit.

Hermetically sealed pumps ensure a safe and controlled conveying of refrigerants. Besides absolute tightness

HERMETIC refrigeration pumps feature the following:

- long service life
- low operating costs
- rapid and reduced acquisition and stockkeeping of spare parts.

## SINGLE-STAGE CANNED MOTOR PUMPS



### *General*

HERMETIC pumps are completely self-contained centrifugal pumps without any shaft sealing, driven electromagnetically by the canned motor. The CNF model has been specially developed for pumping liquefied petroleum gas. This single-stage pump design now allows for the pumping of liquefied petroleum gases with an extremely steep vapour pressure diagram. There is no need for external re-circulation of the partial flow into the suction vessel and the separator.

### *Design*

The pumps use a single-stage impeller mounted directly on an integral induction motor. The pump volute casings and impellers are derived from the standard chemical pumps as defined by EN 22858; ISO 2858.

### *Operating range*

Capacity Q: max. 50 m<sup>3</sup>/h  
Head H: max. 57 m.c.l.

### *Application sector*

Liquid gases as e.g. R 717 (NH<sub>3</sub>), R 22 (Frigen), CO<sub>2</sub>, R 134a, R 404a, R11, R12, baysilone (M3, M5), methanol, silicon oil KT3, syltherm, lithium bromide.

In principle the refrigeration pumps are suitable for use with all refrigerant liquids. Please consult for any fluids not listed above.



### Operation

The partial flow for cooling the motor and lubricating the slide bearings is separated through a ring filter and, after having passed through the motor, is carried back again to the delivery side of the pump. An auxiliary impeller serves to overcome the hydraulic losses encountered along the way. The return of the partial flow to the delivery side ensures that point 3 in the Pressure-Temperature-Diagram (Figure 1) is sufficiently distanced from the boiling-point curve of the diagram. With the CNF model, it is thus possible to pump liquefied petroleum gases with an extremely steep vapour pressure diagram conditions being the same, except for the gas to be pumped.

### Bearings

Slide bearings radially guide the common pump and rotor shaft. This guiding is used during the starting phase and the stopping phase since the guiding function is hydrodynamically taken over by the rotor after the nominal speed of the canned motor has been reached. The axial thrust of our pumps is hydraulically balanced.

### Safety Devices and Monitoring

We recommend to protect HERMETIC pumps against any extreme flow conditions by means of two orifices. Orifice 1 ( $Q_{\min}$ ) ensures the minimum flow rate required for the dissipation of the motor heat loss. Orifice 2 ( $Q_{\max}$ ) ensures the minimum differential pressure in the rotor chamber needed for stabilising the hydraulic axial thrust balance and for avoiding the evaporation of the partial flow. Moreover, this orifice prevents an interruption of the flow of discharge if only a certain minimum suction head is available. Alternatively to orifice 2 ( $Q_{\max}$ ) a constant flow regulator can be installed (see page 20-22).

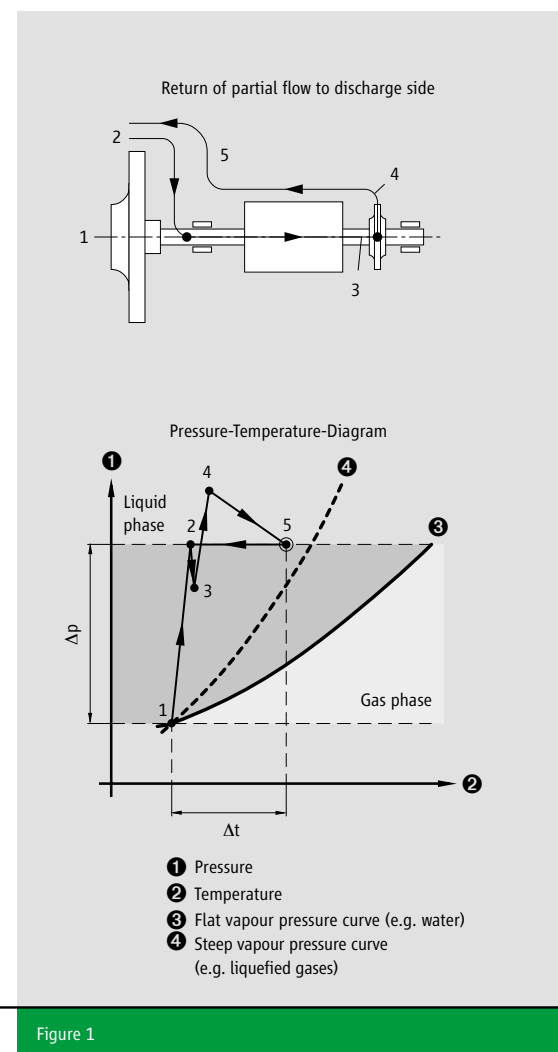
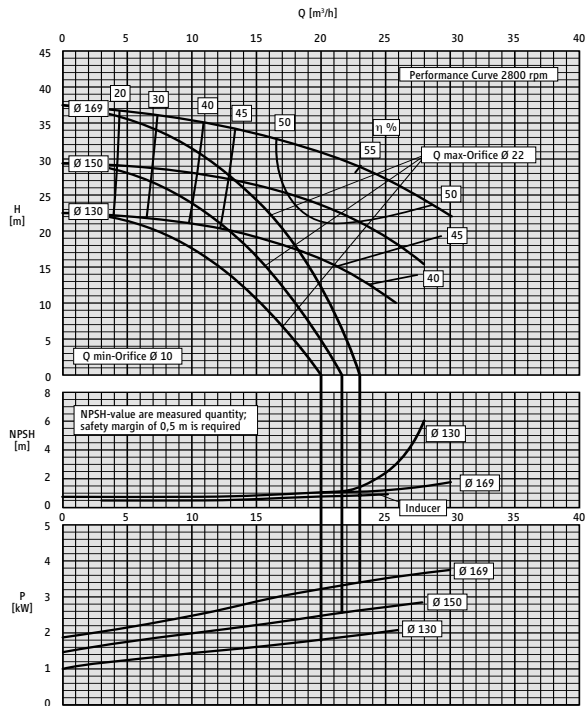

Figure 1

### Performance Curve CNF 40 - 160



Impeller 169 - 130 mm Ø, Width 9 mm

### Performance Curve CNF 40 - 200

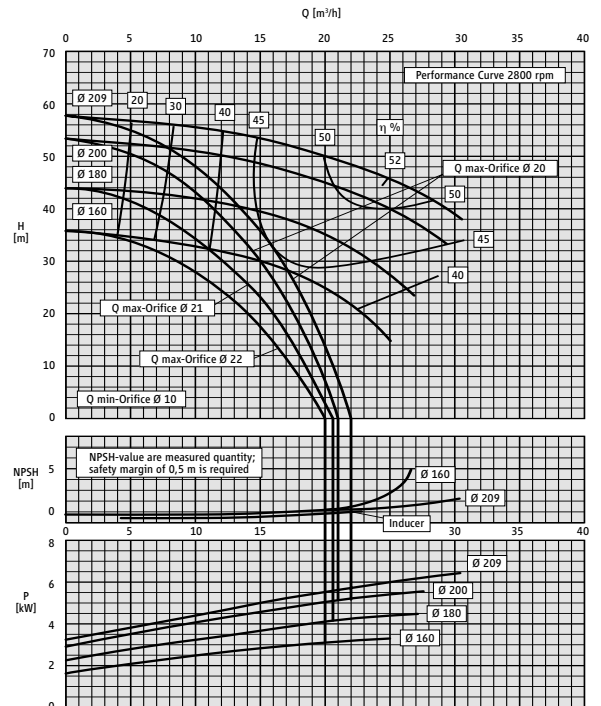

Impeller 209-160 mm Ø, Width 7 mm

### Performance Curve CNF 50 - 160

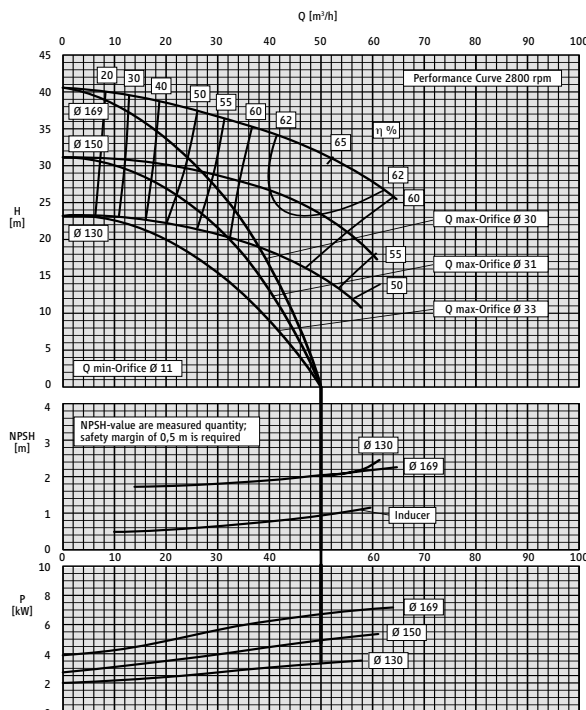

Impeller 169-130 mm Ø, Width 15 mm

### Performance Curve CNF 50 - 200

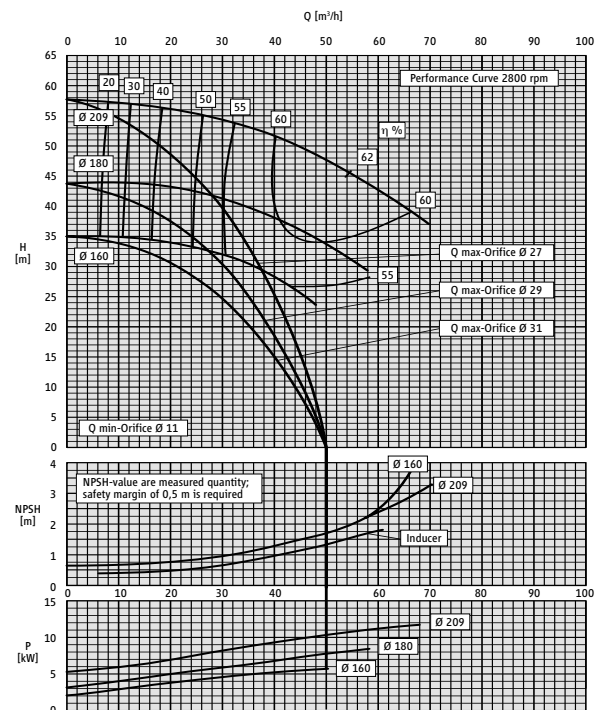

Impeller 209-160 mm Ø, Width 12 mm

**Materials / Pressure Ratings / Flanges**

Casing	JS 1025
Impeller	JL 1040
Bearing	1.4021/carbon
Shaft	1.4021
Stator can	1.4571
Gaskets	AFM 34*
Pressure rating	PN 25**
Flanges	according DIN 2534, PN 25, Form N, groove design according DIN 2512

**Operating Temperature**

Temperature range	-50 °C to +30 °C ***
-------------------	----------------------

**Canned Motors**

Power	up to 13,5 kW
Rotating speed	2800 rpm or 3500 rpm
Voltage	220, 230, 380, 400, 415, 440, 460, 500, 575, 660, or 690 V
Frequency	50 or 60 Hz (frequency regulation possible)
Enclosure	Motor/Rotor IP 64 / IP 67

\* non asbestos

\*\* PN 40 on demand

\*\*\* further temperatures on demand

**CNF-Design**

Type	Motor	Pump data		Motor data		Weight kg
		Q min. required m <sup>3</sup> /h	Q max. permissible m <sup>3</sup> /h	Power kW	Rated current at 400V/ Amp.	
CNF 40 – 160	AGX 3,0	4,0	20,0 – 23,0	3,0	7,1	58,0
	AGX 4,5	4,0	20,0 – 23,0	4,5	10,4	66,0
	AGX 6,5	4,0	20,0 – 23,0	6,5	15,2	69,0
	AGX 8,5	4,0	20,0 – 23,0	8,5	19,0	80,0
CNF 40 – 200	AGX 4,5	4,0	20,0 – 22,0	4,5	10,4	74,0
	AGX 6,5	4,0	20,0 – 22,0	6,5	15,2	77,0
	AGX 8,5	4,0	20,0 – 22,0	8,5	19,0	90,0
	CKPx 12,0	4,0	20,0 – 22,0	13,5	31,0	122,0
CNF 50 – 160	AGX 4,5	6,0	50,0	4,5	10,4	77,0
	AGX 6,5	6,0	50,0	6,5	15,2	80,0
	AGX 8,5	6,0	50,0	8,5	19,0	91,0
	CKPx 12,0	6,0	50,0	13,5	31,0	118,0
CNF 50 – 200	AGX 6,5	6,0	50,0	6,5	15,2	82,0
	AGX 8,5	6,0	50,0	8,5	19,0	96,0
	CKPx 12,0	6,0	50,0	13,5	31,0	125,0

# List of parts CNF

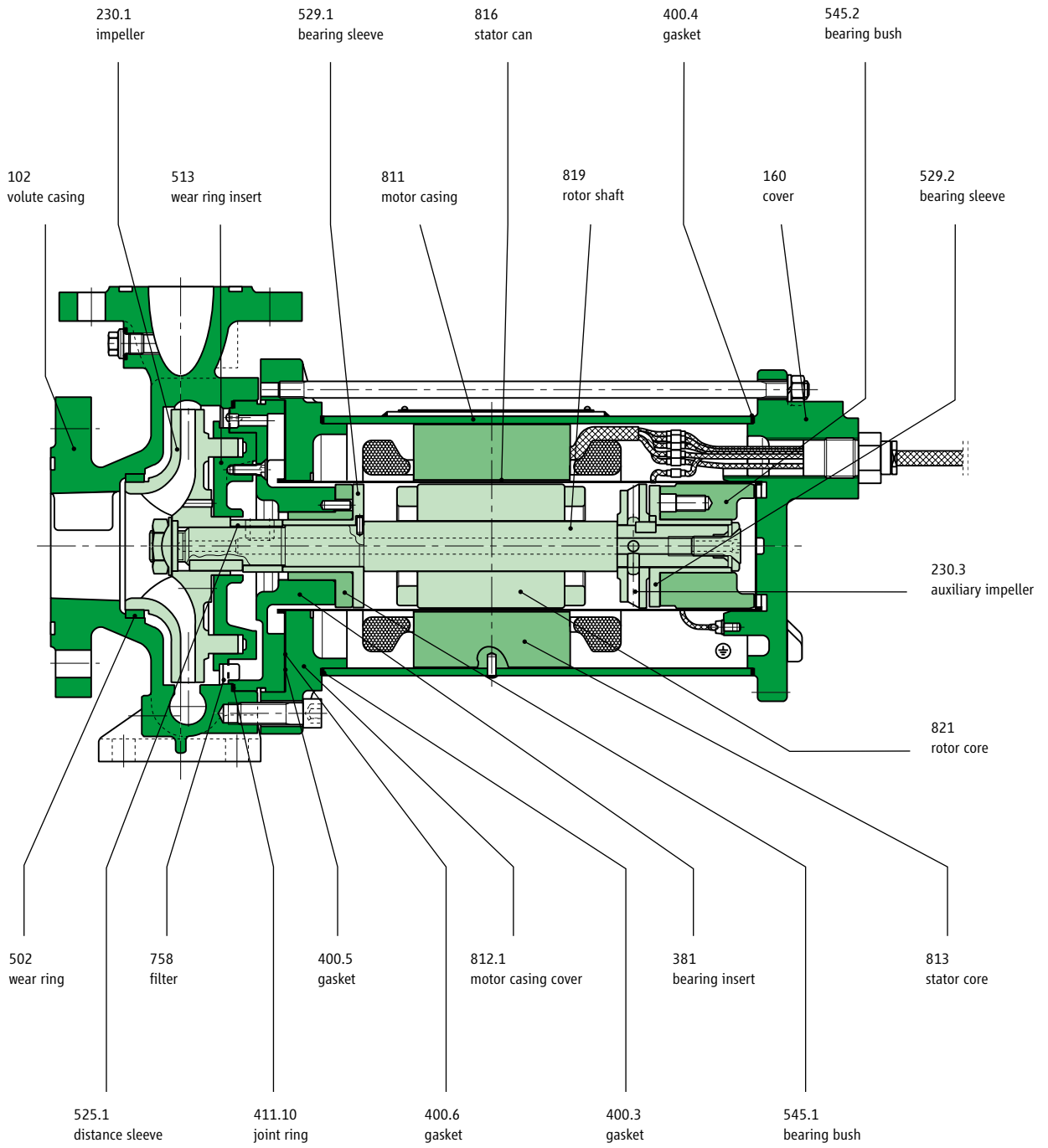

Dimensional drawing for motor type:  
AGX 3,0 / AGX 4,5 / AGX 6,5

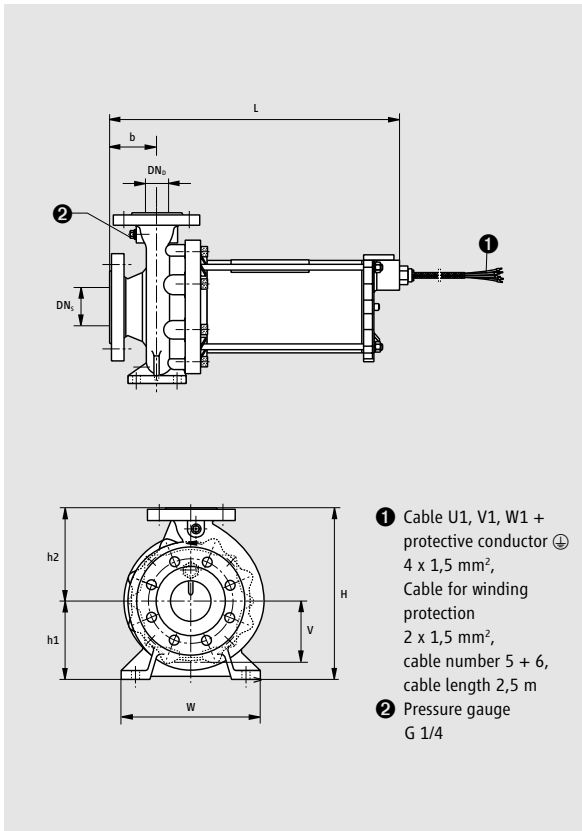

Dimensional drawing for motor type:  
AGX 8,5 / CKPx 12,0

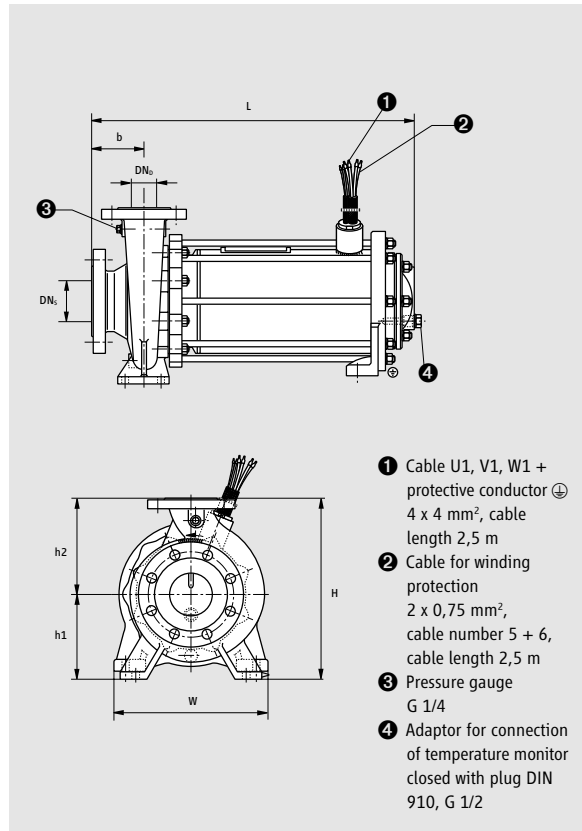

CNF-Design

Dimension	CNF	CNF	CNF	CNF	CNF	CNF	CNF	CNF
	40 – 160	40 – 160	40 – 200	40 – 200	50 – 160	50 – 160	50 – 200	50 – 200
	AGX	AGX	AGX	AGX	AGX	AGX	AGX	AGX
	3,0 to 6,5	8,5	4,5/6,5	8,5/12,0	4,5/6,5	8,5/12,0	6,5	8,5/12,0
Length/L	506	575	526	595/620	526	595/620	526	595/620
Width/W	240	240	265	265/290	265	265/290	265	265/290
Height/H	292	292	340	340	340	340	360	360
h1	132	132	160	160	160	160	160	160
h2	160	160	180	180	180	180	200	200
b	80	80	100	100	100	100	100	100
v	100	100	115	115	108	108	118	118
DN <sub>s</sub>	65	65	65	65	80	80	80	80
DN <sub>d</sub>	40	40	40	40	50	50	50	50

## MULTISTAGE CANNED MOTOR PUMPS



### *General*

The CAM und CAMR range of HERMETIC pumps are completely closed. They operate using the canned motor principle which removes the need for any shaft seal. The CAM and CAMR ranges have been developed especially for the refrigeration applications, their features include:

- Low NPSH values
- Pump built in two to six stages to suit the application
- Able to pump 14 m<sup>3</sup>/h with a suction head of only 1,0 m
- Suitable for pumping ammonia, freons and other refrigerants
- The machines were examined by several classification companies and also have approval for use on ships.

The CAMR range is a special version of the CAM 2 range designed for compact plants with small collecting vessels.

The design enables:

- Space saving by mounting the pump directly under the vessel
- Escaping of gas through the suction port, allowing shorter re-starting times
- The hydraulic data and NPSH value are identical to the CAM 2.

### *Design*

The pumps use multistage impeller mounted directly on an integral induction motor.

### *Operating range*

Capacity Q: max. 35 m<sup>3</sup>/h  
Head H: max. 130 m.c.l.

### *Application sector*

Liquid gases as e.g. R 717 (NH<sub>3</sub>), R 22 (Frigen), CO<sub>2</sub>, R 134a, R 404a, R 11, R 12, baysilone (M3, M5), methanol, silicon oil KT3, syltherm, lithium bromide.

In principle the refrigeration pumps are suitable for use with all refrigerant liquids. Please consult for any fluids not listed above.



### Operation

The partial current for the cooling of the motor and for the lubricating of the bearing is taken from the last impeller on the discharge side and led through the motor space. It is led back through the sleeve shaft not to the suction side of the pump but between two impellers in a region with increased pressure. The point 3, which corresponds to the highest heating in the pressure-temperature-diagram, is sufficiently distanced from the vapour diagram, in order to avoid a boiling out inside the pump.

### Bearings

Slide bearings are lubricated by the processed liquid radially guide the pump shaft and the rotor shaft. This guiding, however, takes place only during the starting phase and the stopping phase, since the guiding function is hydrodynamically taken over by the rotor after the nominal speed of the canned motor has been reached. The axial thrust of our pumps is hydraulically balanced.

### Safety Devices and Monitoring

We recommend to protect HERMETIC pumps against any extreme flow conditions by means of two orifices. Orifice 1 ( $Q_{\min}$ ) ensures the minimum flow rate required for the dissipation of the motor heat loss. Orifice 2 ( $Q_{\max}$ ) ensures the minimum differential pressure in the rotor chamber needed for stabilising the hydraulic axial thrust balance and for avoiding the evaporation of the partial flow. Moreover, this orifice prevents an interruption of the flow of discharge if only a certain minimum suction head is available. Alternatively to orifice 2 ( $Q_{\max}$ ) a constant flow regulator can be installed (see page 20-22).

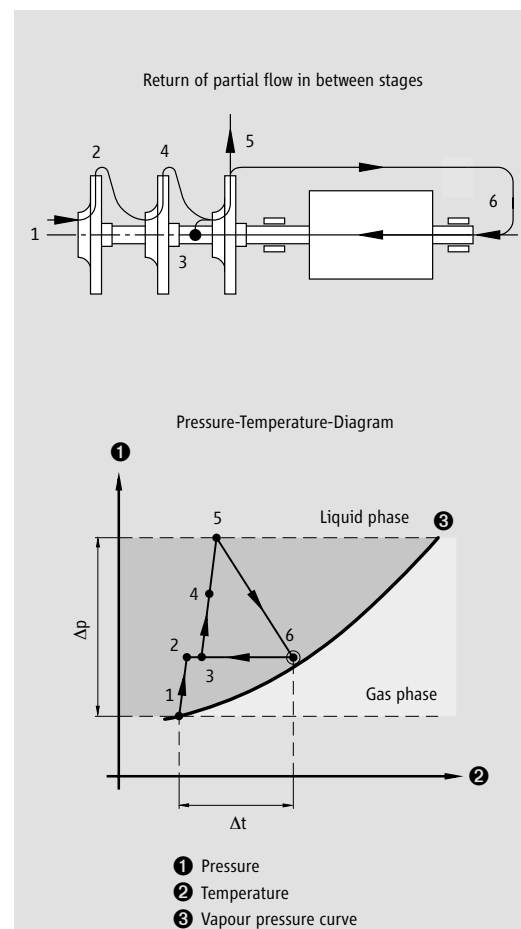
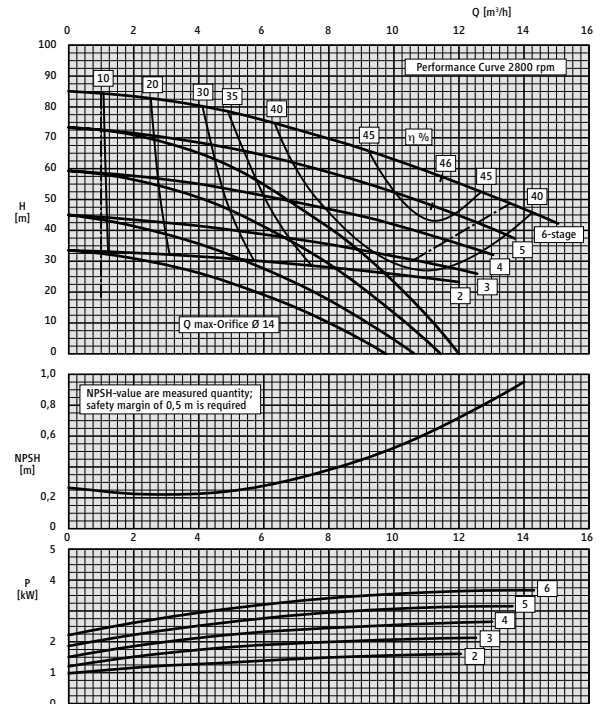

Figure 2

### Performance Curve CAM 1



### Performance Curve CAM 2 and CAMR 2



### Performance Curve CAM 3

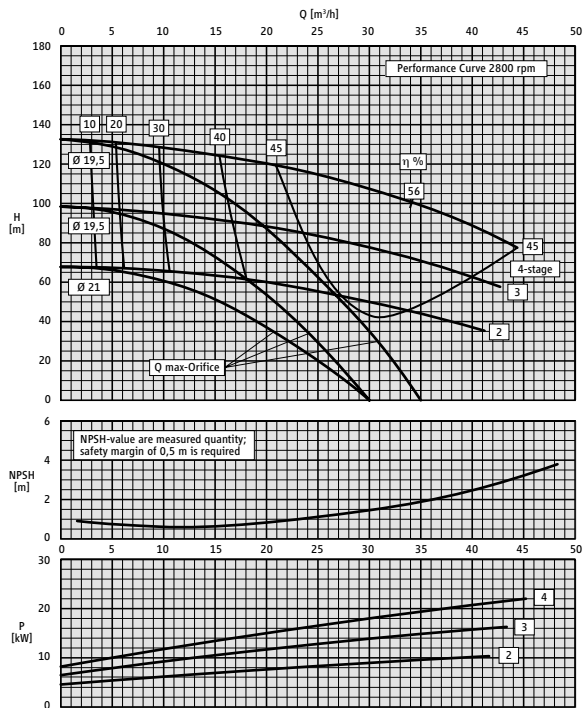

**Materials / Pressure Ratings / Flanges**

Casing	JS 1025
Suction cover (Suction casing CAMR 2)	JS 1025
Stage casing (CAM 1, CAM 2, CAMR 2)	1.0460
Stage casing (CAM 3)	JS 1025
Diffuser insert (Diffuser CAM 3)	JL 1030
Impellers	JL 1030
Bearing	1.4021/carbon
Shaft	1.4021
Stator can	1.4571
Gaskets	AFM 34*
Pressure rating	PN 25**
Flanges	according DIN 2534, PN 25, Form N, groove design according DIN 2512

**Operating Temperature**

Temperature range	-50 °C to +30 °C ***
-------------------	----------------------

**Canned Motors**

Power	up to 22,0 kW
Rotating speed	2800 rpm or 3500 rpm
Voltage	220, 230, 380, 400, 415, 440, 460, 500, 575, 660, or 690 V
Frequency	50 or 60 Hz (frequency regulation possible)
Enclosure	Motor/Rotor IP 64 / IP 67

\* non asbestos

\*\* PN 40 on demand

\*\*\* further temperatures on demand

**CAM / CAMR-Design**

Type	Motor	Pump data		Motor data		Weight kg
		Q min. required m <sup>3</sup> /h	Q max. permissible m <sup>3</sup> /h	Power kW	Rated current at 400V/ Amp.	
CAM 1/2	AGX 1,0	0,5	3,5	1,0	2,7	27,0
CAM 1/3	AGX 1,0	0,5	4,0	1,0	2,7	28,0
CAM 1/4	AGX 1,0	0,5	4,0	1,0	2,7	29,0
CAM 1/5	AGX 1,0	0,5	4,0	1,0	2,7	30,0
CAM (R) 2/2	AGX 3,0	1,0	10,0	3,0	7,1	48,0
CAM (R) 2/3	AGX 3,0	1,0	10,5	3,0	7,1	52,0
CAM (R) 2/3	AGX 4,5	1,0	10,5	4,5	10,4	60,0
CAM (R) 2/4	AGX 3,0	1,0	11,5	3,0	7,1	56,0
CAM (R) 2/4	AGX 4,5	1,0	11,5	4,5	10,4	68,0
CAM (R) 2/5	AGX 3,0	1,0	12,5	3,0	7,1	60,0
CAM (R) 2/5	AGX 4,5	1,0	12,5	4,5	10,4	74,0
CAM (R) 2/5	AGX 6,5	1,0	12,5	6,5	15,2	77,0
CAM (R) 2/6	AGX 3,0	1,0	13,5	3,0	7,1	64,0
CAM (R) 2/6	AGX 4,5	1,0	13,5	4,5	10,4	78,0
CAM (R) 2/6	AGX 6,5	1,0	13,5	6,5	15,2	81,0
CAM 3/2	AGX 8,5	6,0	30,0	8,5	19,0	120,0
CAM 3/2	CKPx 12,0	6,0	30,0	13,5	31,0	150,0
CAM 3/2	CKPx 19,0	6,0	30,0	22,0	49,5	195,0
CAM 3/3	AGX 8,5	6,0	30,0	8,5	19,0	138,0
CAM 3/3	CKPx 12,0	6,0	30,0	13,5	31,0	168,0
CAM 3/3	CKPx 19,0	6,0	30,0	22,0	49,5	213,0
CAM 3/4	CKPx 12,0	6,0	35,0	13,5	31,0	186,0
CAM 3/4	CKPx 19,0	6,0	35,0	22,0	49,5	231,0

# List of parts CAM 1 / CAM 2

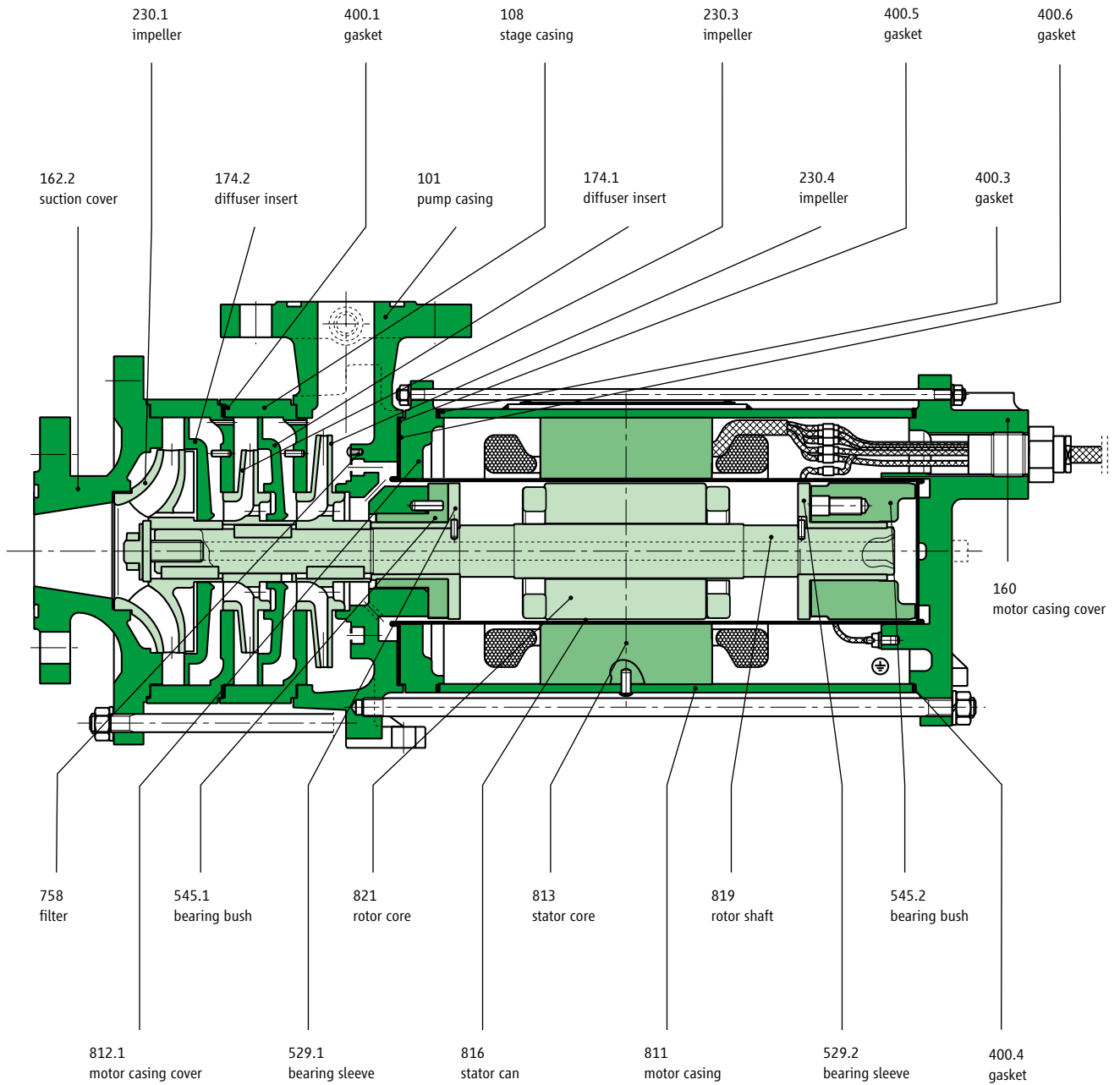

Dimensional drawing for motor type: AGX 1,0 / AGX 3,0 / AGX 4,5 / AGX 6,5

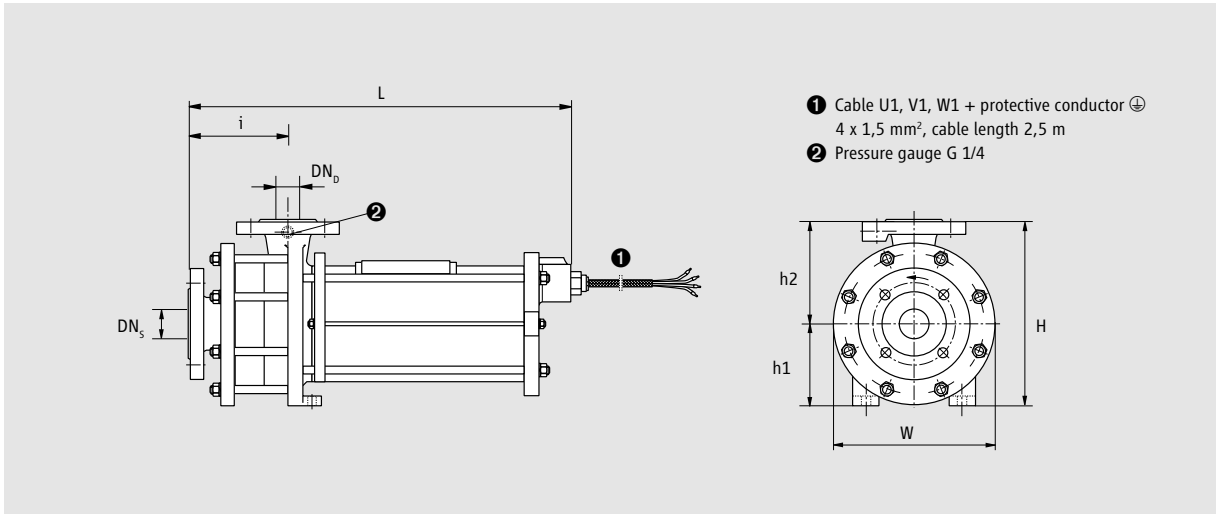

- 1 Cable U1, V1, W1 + protective conductor ⊕  
4 x 1,5 mm<sup>2</sup>, cable length 2,5 m
- 2 Pressure gauge G 1/4

CAM 1-Design

Dimension	CAM	CAM	CAM	CAM
	1/2-stage	1/3-stage	1/4-stage	1/5-stage
	AGX	AGX	AGX	AGX
	1,0	1,0	1,0	1,0
Length/L	419	447	475	503
Width/W	160	160	160	160
Height/H	210	210	210	210
h1	90	90	90	90
h2	120	120	120	120
i	112	140	168	196
DN <sub>s</sub>	25	25	25	25
DN <sub>o</sub>	20	20	20	20

CAM 2-Design

Dimension	CAM	CAM	CAM	CAM	CAM
	2/2-stage	2/3-stage	2/4-stage	2/5-stage	2/6-stage
	AGX	AGX	AGX	AGX 3,0/	AGX3,0/
	3,0	3,0/4,5	3,0/4,5	4,5/6,5	4,5/6,5
Length/L	536	577	618	659	700
Width/W	218	218	218	218	218
Height/H	250	250	250	250	250
h1	110	110	110	110	110
h2	140	140	140	140	140
i	135	176	217	258	299
DN <sub>s</sub>	40	40	40	40	40
DN <sub>o</sub>	32	32	32	32	32

# List of parts CAMR 2

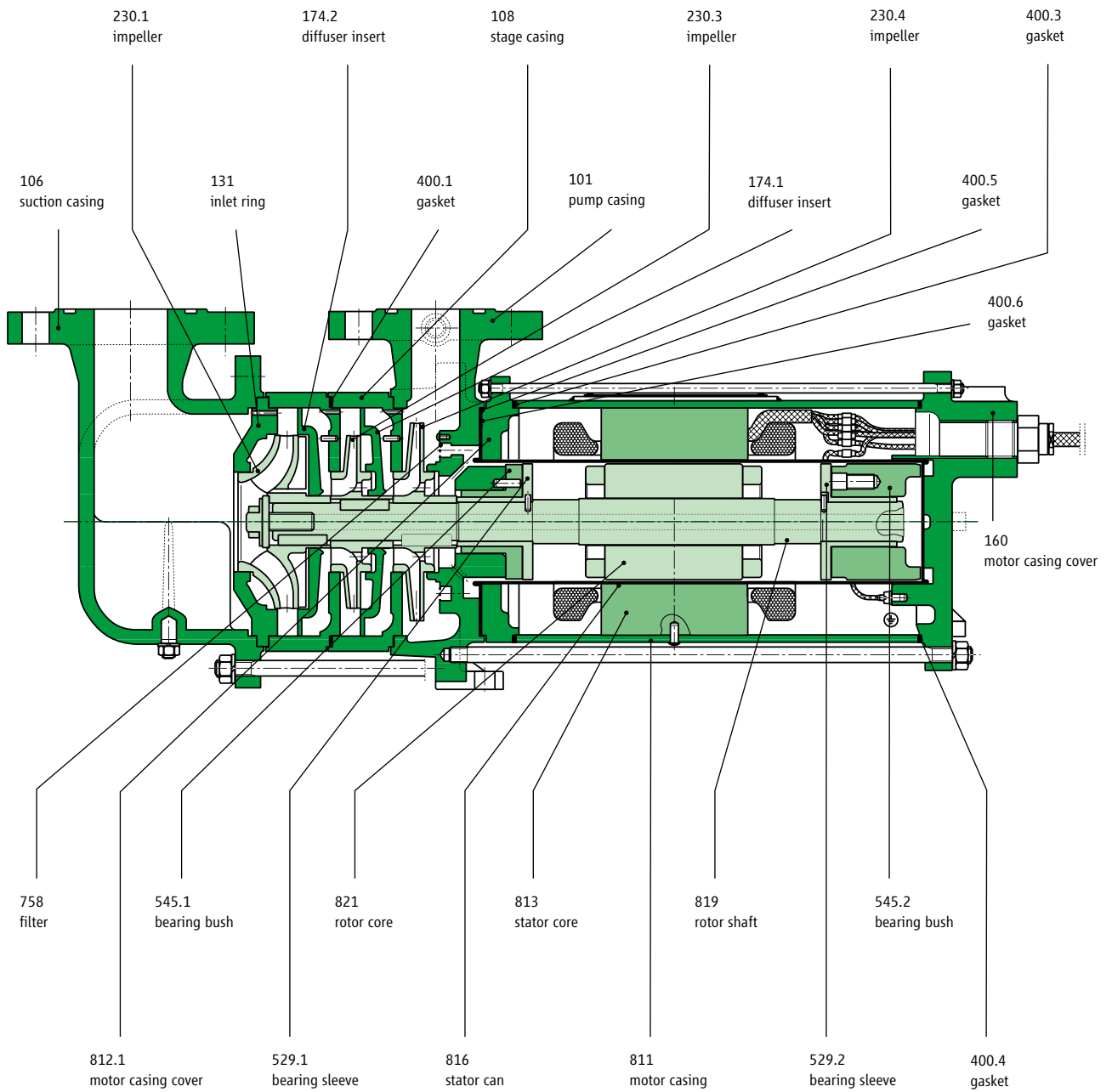

Dimensional drawing for motor type: AGX 3,0 / AGX 4,5 / AGX 6,5

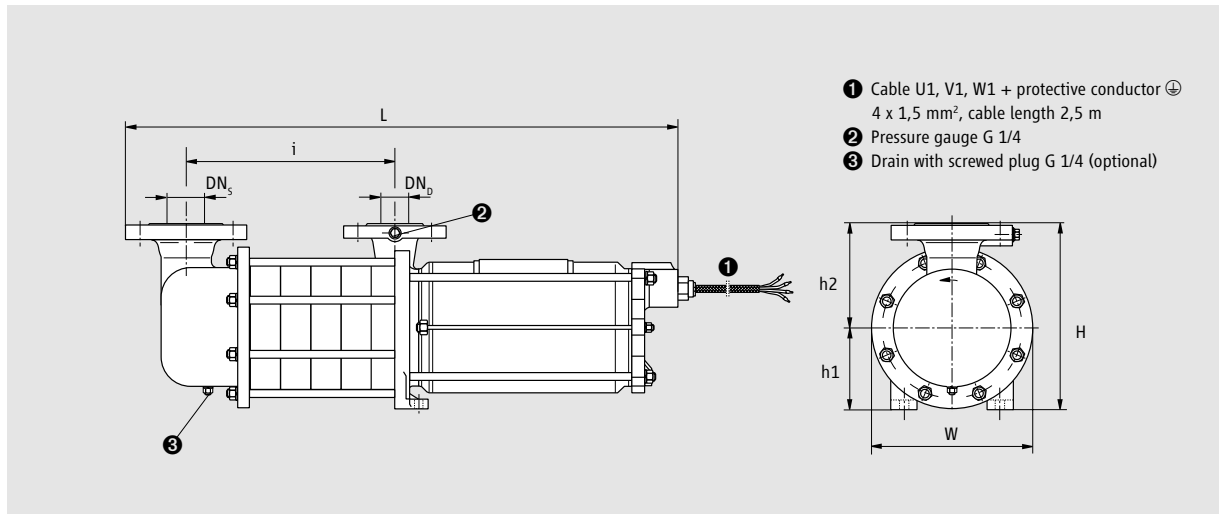

- ❶ Cable U1, V1, W1 + protective conductor ⊕  
4 x 1,5 mm<sup>2</sup>, cable length 2,5 m
- ❷ Pressure gauge G 1/4
- ❸ Drain with screwed plug G 1/4 (optional)

CAMR 2-Design

Dimension	CAMR 2/2-stage	CAMR 2/3-stage	CAMR 2/4-stage	CAMR 2/5-stage	CAMR 2/6-stage
	AGX 3,0	AGX 3,0/4,5	AGX 3,0/4,5	AGX 3,0/ 4,5/6,5	AGX 3,0/ 4,5/6,5
Length/L	649	690	731	772	813
Width/W	218	218	218	218	218
Height/H	250	250	250	250	250
h1	110	110	110	110	110
h2	140	140	140	140	140
i	160	201	242	283	324
DN <sub>s</sub>	50	50	50	50	50
DN <sub>o</sub>	32	32	32	32	32

# List of parts CAM 3

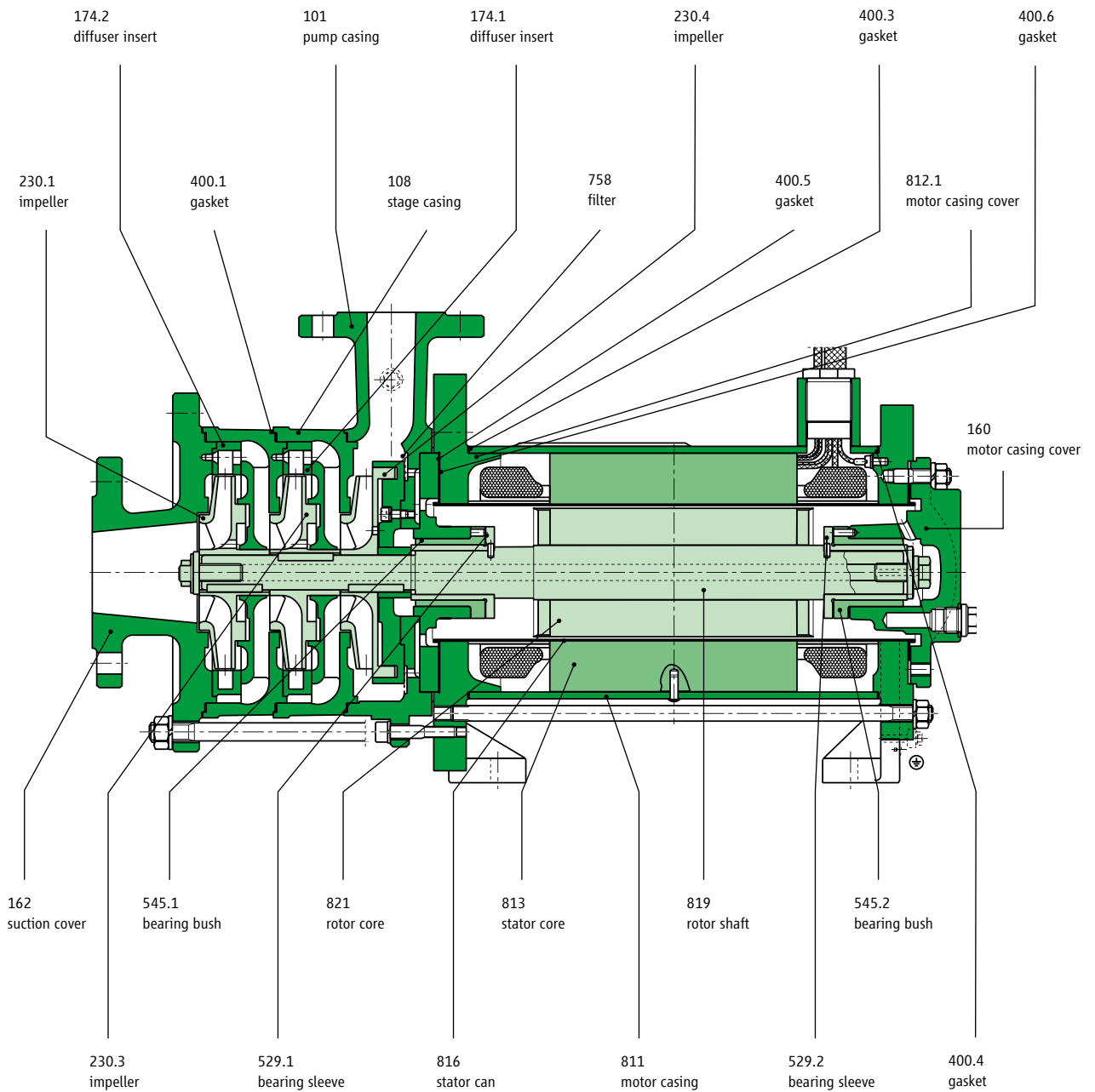

Dimensional drawing for motor type: AGX 8,5 / CKPx 12,0 / CKPx 19,0

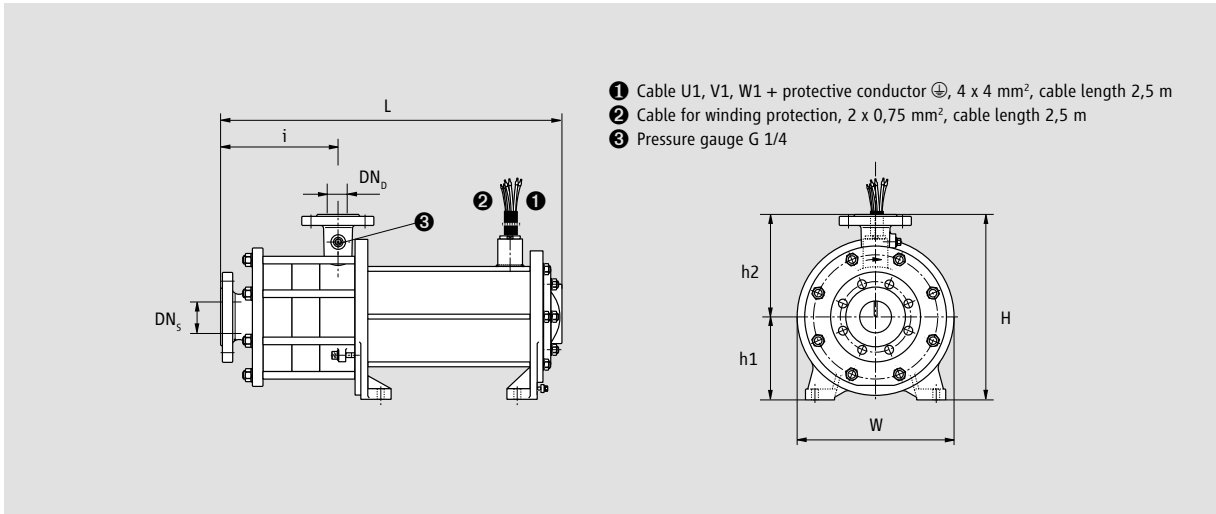

CAM 3-Design

Dimension	CAM 3/2-stage	CAM 3/2-stage	CAM 3/2-stage	CAM 3/3-stage	CAM 3/3-stage	CAM 3/3-stage	CAM 3/4-stage	CAM 3/4-stage
	AGX 8,5	CKPx 12,0	CKPx 19,0	AGX 8,5	CKPx 12,0	CKPx 19,0	CKPx 12,0	CKPx 19,0
Length/L	597	642	707	654	699	764	756	821
Width/W	250	290	340	250	290	340	290	340
Height/H	355	380	380	355	380	380	380	380
h1	145	170	170	145	170	170	170	170
h2	210	210	210	210	210	210	210	210
i	184	184	184	241	241	241	298	298
DN <sub>c</sub>	65	65	65	65	65	65	65	65
DN <sub>b</sub>	40	40	40	40	40	40	40	40

## CONSTANT FLOW REGULATOR

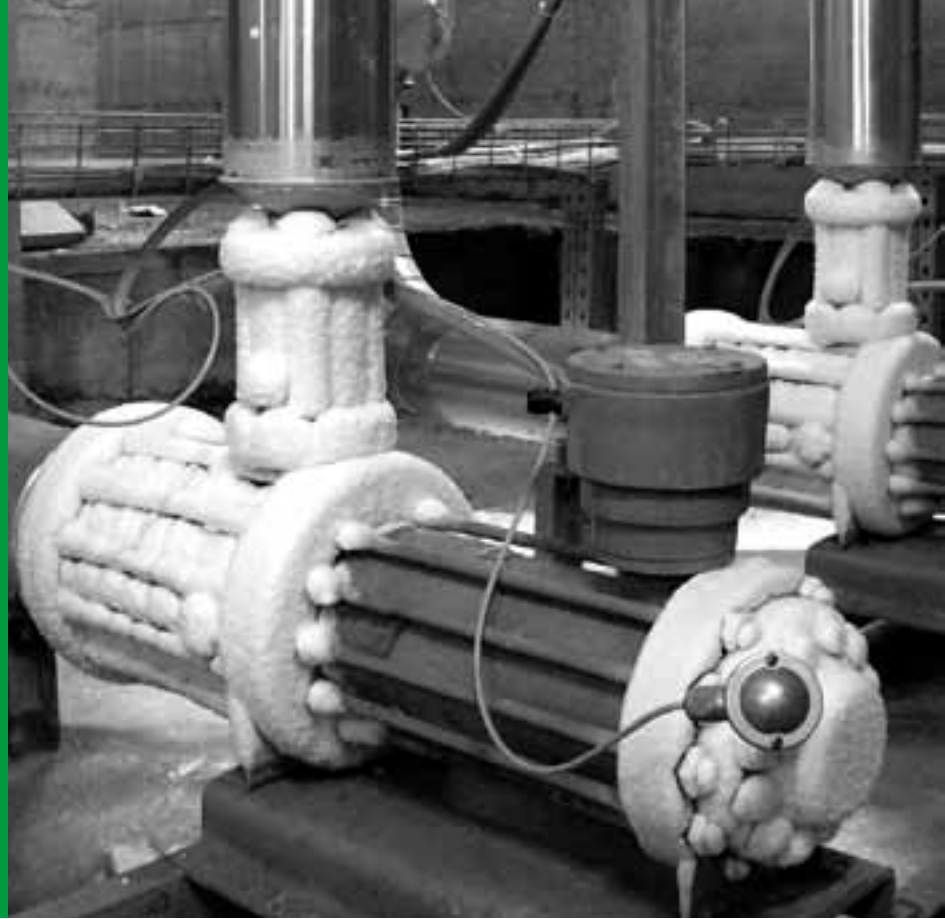

### *General*

The constant flow regulator has been developed especially for refrigeration plants. These valves facilitate a safe operation of pumps in a sphere, which normally is impossible for pumps with  $Q_{\max}$ -orifice. Figure 3 shows the additional operational range which is obtained by the application of a constant flow regulator instead of a  $Q_{\max}$ -orifice. Often a smaller pump, more economically priced, can be installed.

### *Operation*

The constant flow regulator must remain full of fluid during system operation. The operation of the valve is dependent on the characteristics of the flowing media. It is therefore important that when ordering a valve, complete fluid specifications are included. Specific gravity is the most important value for the correct design of a valve.

### *Maintenance*

There is no need for regular maintenance of the constant flow regulator and no readjustment is required. Spare cartridge assemblies may be ordered when required.

**Application sector**

Constant flow regulators are intended to be installed at the outlet of refrigerant liquid pumps. These regulators accurately control the flow rate and enable pumps to safely function in a range not normally available to pumps using discharge orifices. They enable pumps to operate closer to their unrestricted pump flow curve but not to exceed the calibrated quantity of flow. They will prevent a pump from operating in a region which exceeds its motor horsepower rating and required NPSH. (see diagram at Figure 3)

**Principles of operation**

Flow limitation is achieved by specially shaped ports in a spring-loaded, moving piston (Figure 4). Due to the pressure differential before and behind the piston, it oscillates which in turn changes the exposed area of the orifice. As the pressure differential increases, the cartridge moves to counterbalance the spring force. This displacement moves part of the variable port past the stationary orifice plate. If the pressure differential exceeds a specified maximum (pressure differential control range = 8 bar), the spring is fully compressed and the valve acts as a fixed orifice device. This also operates if the pressure drops beyond the required minimum. If the pressure differential exceeds a specified maximum (pressure differential control range = 8 bar), the spring is fully compressed and the valve acts as a fixed orifice device. This also operates if the pressure drops beyond the required minimum.

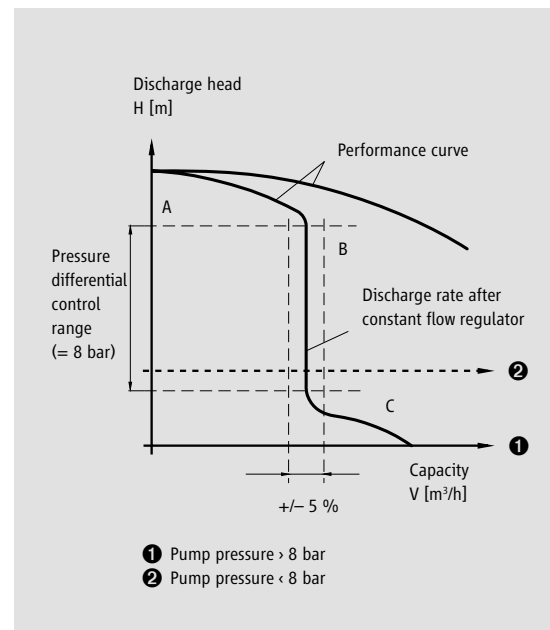

Figure 3

Functional-Diagram Valve

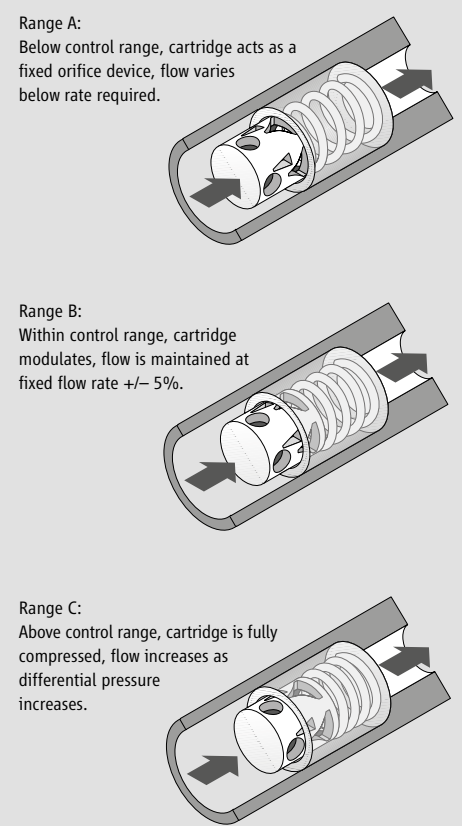
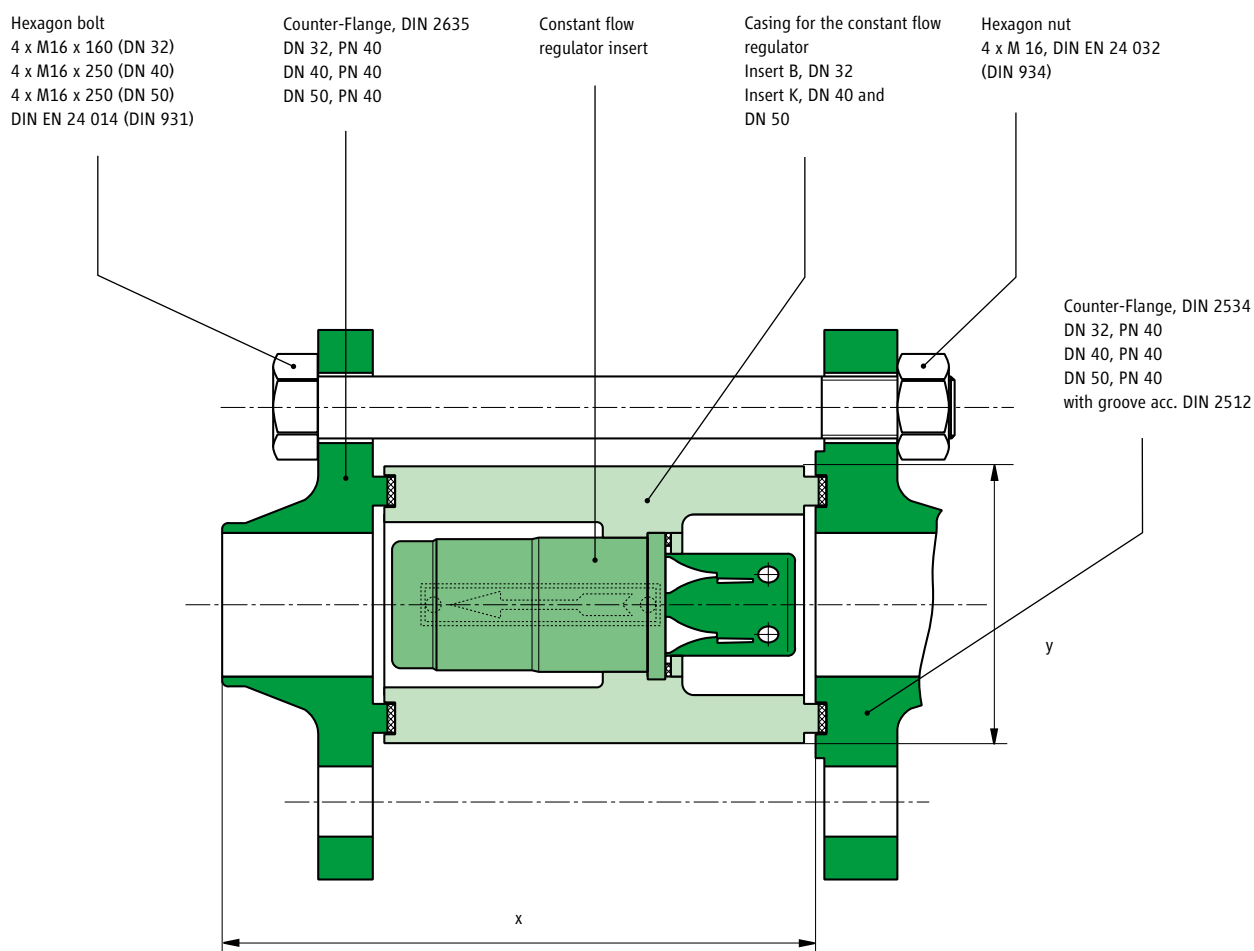

Figure 4

# List of parts



*The valve is available for the following flow rates:*

Model	NW	for pump type	Dimension x / y	max. flow rates for H <sub>2</sub> O
NQL-61-44-8	32	CAM 2 / CAMR 2	150 / 70	9,99 m <sup>3</sup> /h
NQL-62-85-8	40	CAM 3 / CNF 40 – 160 / CNF 40 – 200	224 / 90	19,30 m <sup>3</sup> /h
	50	CNF 50 – 160 / CNF 50 – 200	227 / 100	
NQL-62-110-8	40	CAM 3 / CNF 40 – 160 / CNF 40 – 200	224 / 90	25,00 m <sup>3</sup> /h
	50	CNF 50 – 160 / CNF 50 – 200	227 / 100	
NQL-62-150-8	40	CAM 3	224 / 90	34,10 m <sup>3</sup> /h
	50	CNF 50 – 160 / CNF 50 – 200	227 / 100	

### Orifice Plates

It is possible to protect a HERMETIC pump from extreme flow conditions by installing 2 orifice plates. The  $Q_{\min}$  - orifice guarantees the necessary flow for the motor cooling and the bearing lubrication. It also allows correct venting of the pump at standstill. The  $Q_{\max}$  - orifice ensures that the minimum differential pressure is maintained in the rotor space. This is necessary for the stabilization of the hydraulic axial thrust compensation and for the avoidance of the partial current vaporization. You can see the installation of the orifices on page 3.

### Inducer

Inducers are axial impellers, which are installed closely in front of the first impeller of a centrifugal pump on the same shaft and which cause an additional static pressure in front of the impeller (Figure 5). They are particularly used where the NPSHA is not sufficient in order to reduce the NPSHR value of the pump. In many cases inducers are also used preventatively if the resistances of the suction line cannot be determined exactly or if the suction head is unpredictable, or if there is a change of the overpressure above the vapour pressure of the liquid. Furthermore inducers are particularly suitable for the transport of liquids, which are affected with dissolved gases. In both cases the inducer can serve to avoid cavitation and minimum capacity.

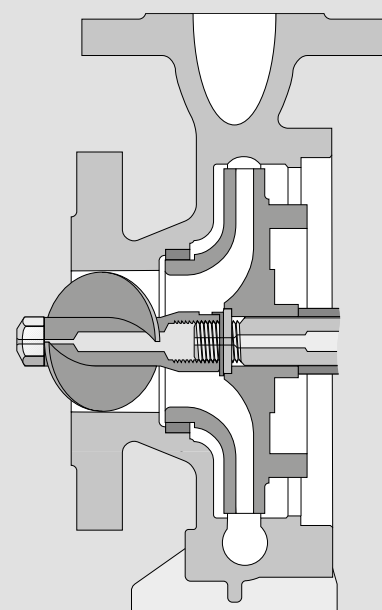

Figure 5

## Convincing service.

Important features are readiness, mobility, flexibility, availability and reliability. We are anxious to ensure a pump operation at best availability and efficiency to our customers.

### *Installation and commissioning*

- service effected on site by own service technicians

### *Spare part servicing*

- prompt and longstanding availability
- customized assistance in spare part stockkeeping

### *Repair and overhauling*

- professional repairs including test run executed by the parent factory
- or executed by one of our service stations worldwide

### *Retrofit*

- retrofit of your centrifugal pumps by installing a canned motor to comply with the requirements of the IPPC Directive

### *Maintenance and service agreement*

- concepts individually worked out to increase the availability of your production facilities

### *Training and workshops*

- extra qualification of your staff to ensure the course of your manufacture

### **Among others, our products comply with:**

- Directive 2006/42/EC (Machinery Directive)
- Explosion protection acc. to Directive 94/9/EC (ATEX); UL; KOSHA; NEPSI; CQST; CSA; Rostechnadzor
- Directive 96/61/EC (IPPC Directive)
- Directive 1999/13/EC (VOC Directive)
- TA-Luft
- RCC-M, Niveau 1, 2, 3

### **HERMETIC-Pumpen GmbH is certified acc. to:**

- ISO 9001:2008
- GOST; GOST "R"
- Directive 94/9/EC
- AD 2000 HP 0; Directive 97/23/EC
- DIN EN ISO 3834-2
- KTA 1401; AVS D 100 / 50; IAEA 50-C-Q
- Certified company acc. to § 19 I WH