

MODEL INFORMATION
CANNED MOTOR PUMP TYPE CN / CNF

HERMETIC *V-Line*

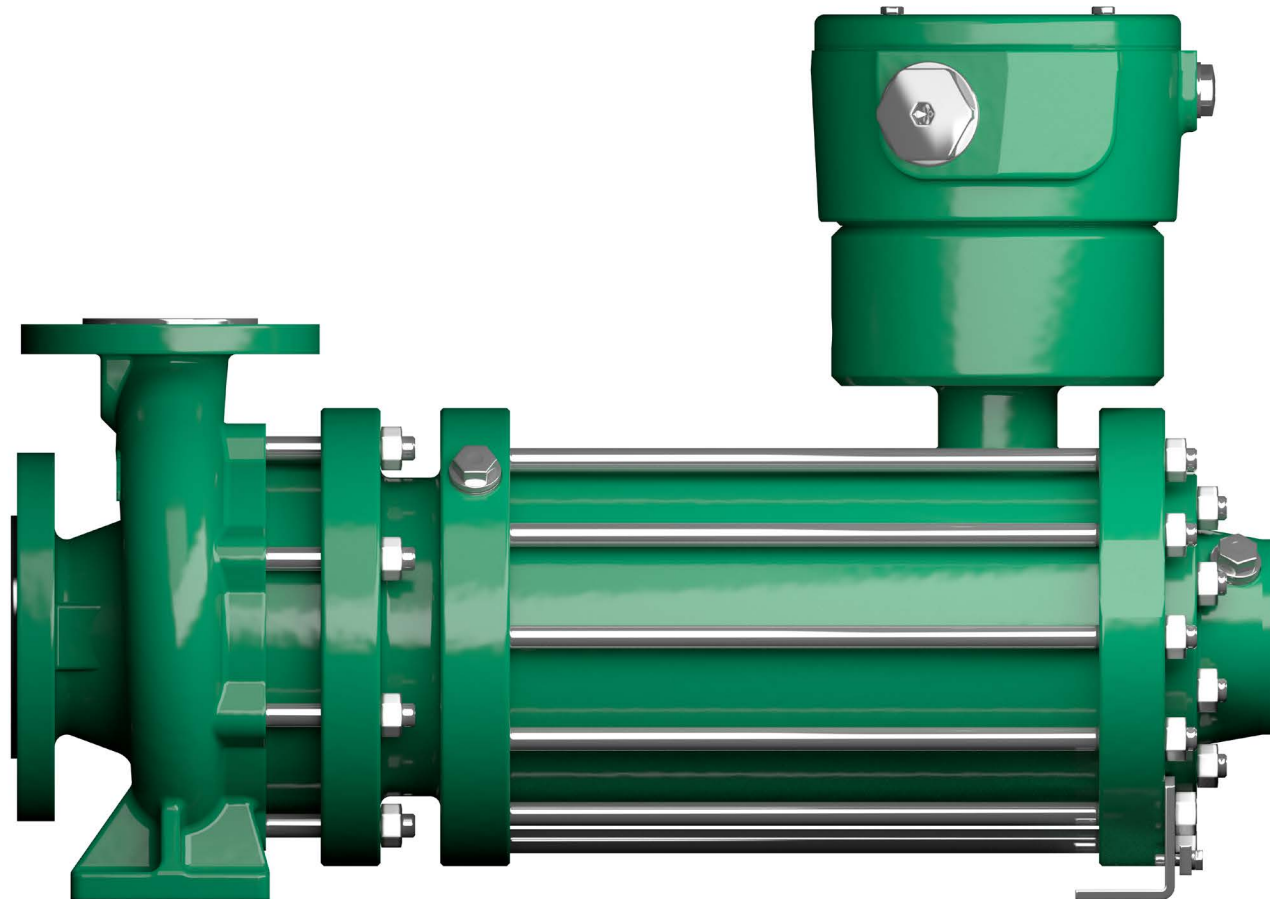

ZART®

simply best balance

Contents

General information	3	Spare parts	16
Characteristic maps	4	Connections	18
3000 rpm 50 Hz	4	Collective measurements	19
3600 rpm 60 Hz	5	Collective measurement drawing	19
Advantages	6	Collective measurement data	20
Technical data	8	Monitoring equipment	22
Modular pump / motor systems	8	Options and accessories	23
Materials	9	Contact	25
Pressure and temperature limits	10		
Canned motors with H-winding	11		
Canned motors with C-winding	12		
Forces and torques	13		
Documentation and tests	15		

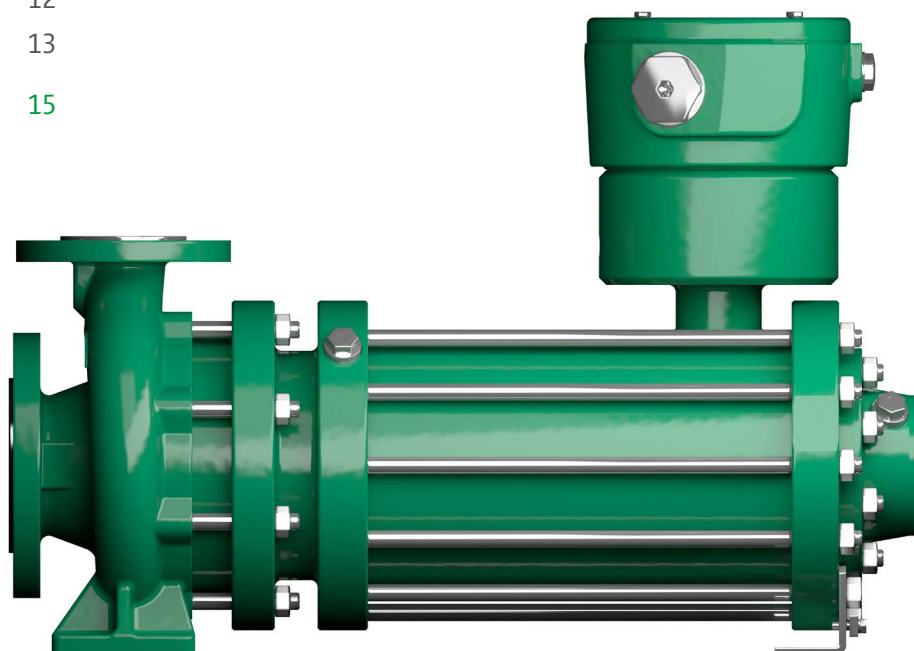

Contents

General information
Characteristic maps
Advantages
Technical data
Documentation and tests
Spare parts
Connections
Collective measurements
Monitoring equipment
Options and accessories
Contact

Information

Operational areas / applications

For the safe transport of aggressive, toxic, hot, explosive, valuable and flammable liquids and liquefied gases.

Model / design

Horizontal, sealless spiral housing pumps in process design with completely closed canned motor with radial impeller, single-stage, single-flow. The connection measurements of the housing comply with EN 22 858 / ISO 2858.

Canned motor pump type CN

The CN model is a standard design of the HERMETIC canned motor pump and is suitable for conveying all common liquids that are not close to steam pressure (not boiling media).

Canned motor pump type CNF

The CNF model is the version for liquefied gases, boiling media and condensate. With an integrated auxiliary impeller and internal fluid return, it is suitable for conveying liquids close to steam pressure.

Drive

The rotor lining, one of our core competences, is manufactured using the compact extrusion method and as a nickel-base alloy, it is an essential component of the highly efficient canned motor. The pressure-resistant enclosed version of our canned motor complies with explosion protection according to Directive 2014 / 34 / EU. The canned motor filled with liquid accelerates to the operating speed in seconds. It is wear-free and maintenance-free during continuous operation due to the hydrodynamic sleeve bearings. The canned motor with low noise and vibration and offers double security to prevent leaks.

Operating data

Frequency:	50 Hz	60 Hz
Pump capacity [Q]:	1.5 to 110 m ³ /h	1.8 to 130 m ³ /h
Pumping head [H]:	12 to 100 m	17 to 145 m
Output power [P2]:	max. 41 kW	max. 48 kW
Conveyed material temperature [t]:	-40 °C to +180 °C	-40 °C to +180 °C
Operating pressure:	up to 25 bar	up to 25 bar

(Extended rating scheme available on request)

Pump and hydraulic denomination

CN 50 – 32 – 200 N34L-2

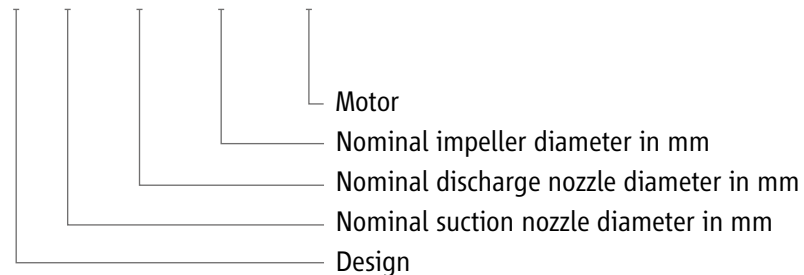

Contents

General information

Characteristic maps

Advantages

Technical data

Documentation and tests

Spare parts

Connections

Collective measurements

Monitoring equipment

Options and accessories

Contact



3000 rpm 50 Hz

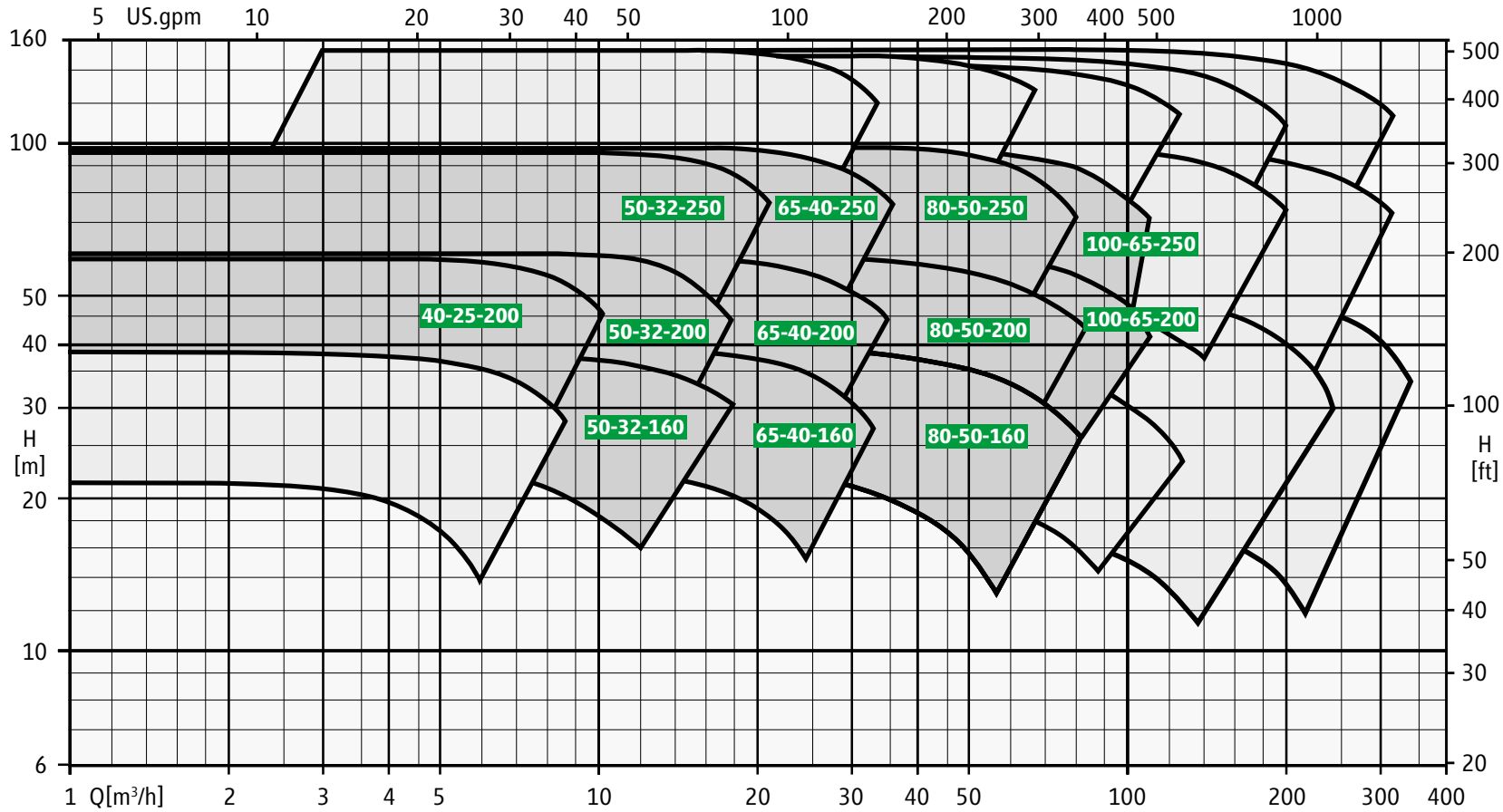

- Contents
- General information
- Characteristic maps**
- Advantages
- Technical data
- Documentation and tests
- Spare parts
- Connections
- Collective measurements
- Monitoring equipment
- Options and accessories
- Contact



3600 rpm 60 Hz

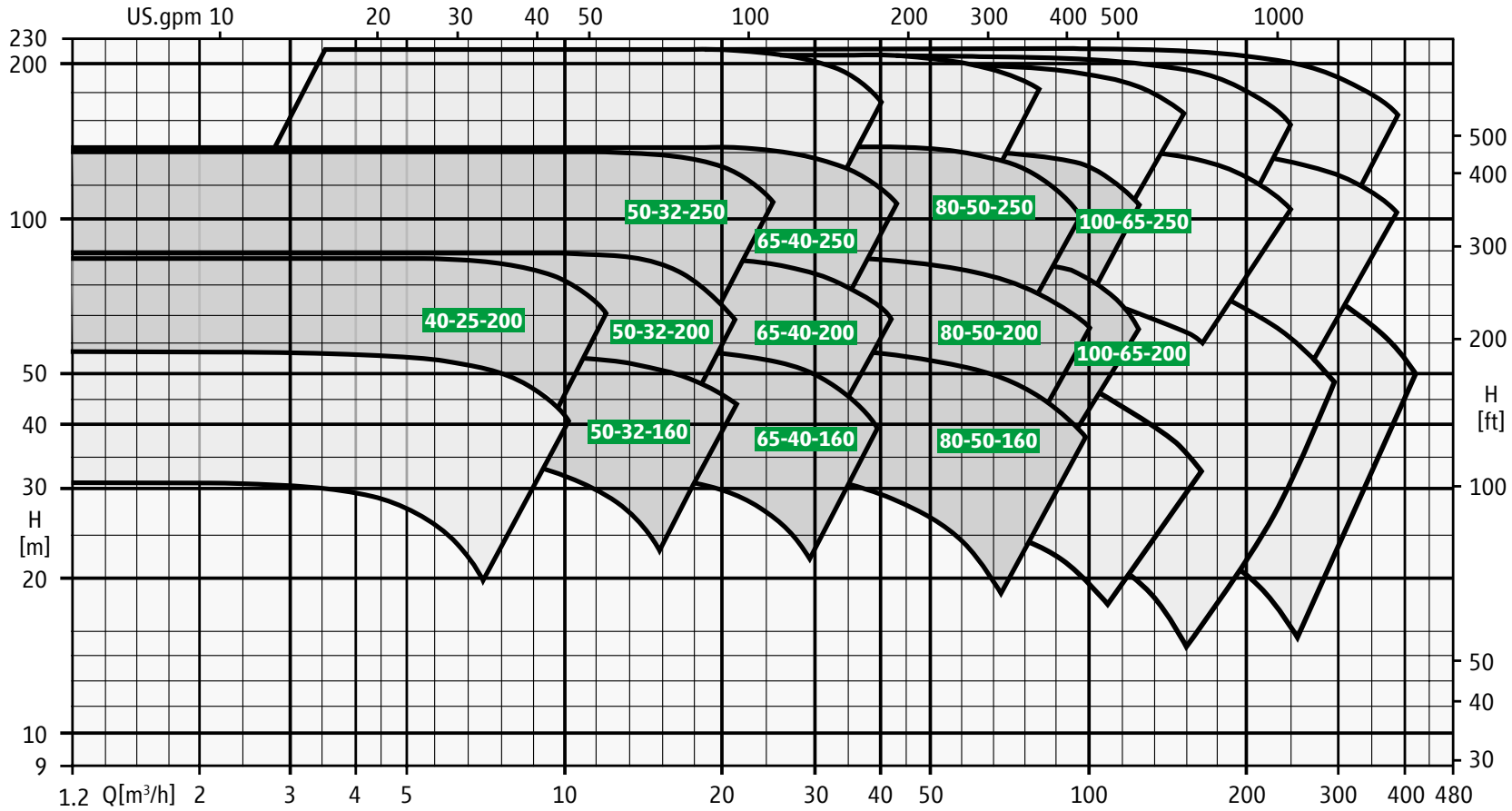

- Contents
- General information
- Characteristic maps**
- Advantages
- Technical data
- Documentation and tests
- Spare parts
- Connections
- Collective measurements
- Monitoring equipment
- Options and accessories
- Contact



Advantages of the canned motor pump

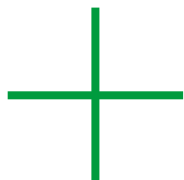

Best Available Pump Technology according to IPCC / TA-LUFT

Leakage-free, long-lasting operation: protection of personnel and environment

No shaft seals

Low space requirement

High level of reliability

Low expenditure for repairs / spare parts

Simple assembly and installation

Long service life of pump and motor

Low life cycle costs

Very smooth running

Contents

General information

Characteristic maps

Advantages

Technical data

Documentation
and tests

Spare parts

Connections

Collective measurements

Monitoring equipment

Options and accessories

Contact



Advantages of the canned motor pump

100% tightness by two safety casings

Corrosion-resistant rotor lining

Explosion-proof motor (2014/34/EU), vacuum-dried N₂-inertised

Thermal motor protection to prevent overload

Standardised flange connections according to EN / ISO / ANSI

High level of functional safety by self-venting

Without shaft seal / sealing system

Standardised hydraulics with a block design and foot mounting

Internal partial flow circulation (also for high steam pressures), no external return line required

Contactless operation by hydrodynamic axial thrust balancing (ZART®)

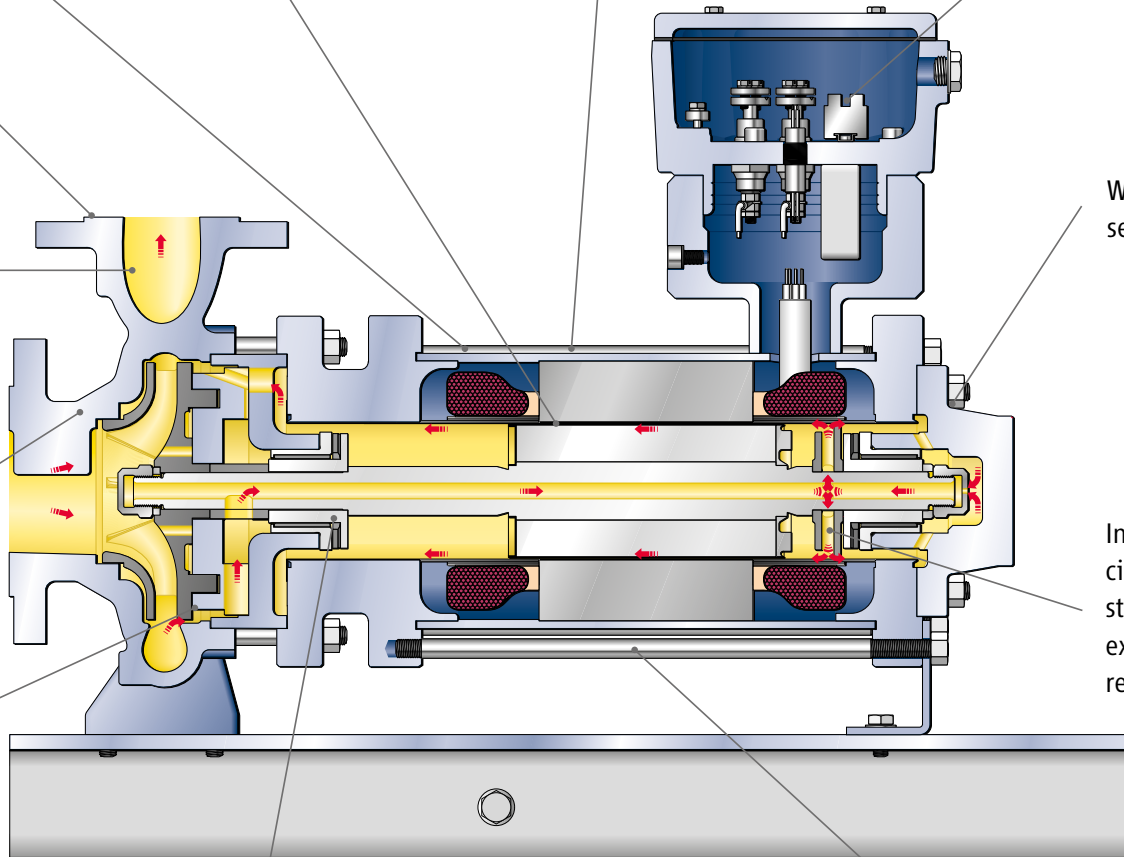

Wear-resistant and smooth running slide bearing (no roller bearings subject to wear)

No coupling (no alignment of pumps / motor shaft required)

- Contents
- General information
- Characteristic maps
- Advantages**
- Technical data
- Documentation and tests
- Spare parts
- Connections
- Collective measurements
- Monitoring equipment
- Options and accessories
- Contact



Modular pump / motor systems

Hydraulics	Motor output power [P2 at 50 Hz / 60 Hz] max.								
	N24N-2 ⁽¹⁾	N34L-2 ⁽¹⁾	T34L-2 C2 ⁽²⁾	N34XL-2 ⁽¹⁾	T54p-2 RC2 ⁽²⁾	N54XL-2 ⁽¹⁾	N64XL-2 ⁽¹⁾	T64r-2 RC2 ⁽²⁾	T74n-2 C2 ⁽²⁾
CN / CNF	6,0 kW / 7,2 kW	8,0 kW / 10,5 kW	7,1 kW / 8,5 kW	14,8 kW / 17,2 kW	8,4 kW / 10,0 kW	24,0 kW / 27,0 kW	41,0 kW / 48,0 kW	13,5 kW / 13,5 kW	33,0 kW / 26,0 kW
40-25-200	■	■			■				
50-32-160	■	■	■		■				
50-32-200			■		■				
50-32-250				■		■			■
65-40-160		■	■	■	■	■		■	
65-40-200		■	■	■	■	■		■	
65-40-250				■		■	■		■
80-50-160		■	■	■	■	■		■	
80-50-200		■		■		■	■	■	
80-50-250				■	■	■	■		■
100-65-200				■		■	■		
100-65-250						■	■		

Extended rating scheme available on request

(1) For liquid temperatures up to 120 °C

(2) For liquid temperatures up to 180 °C

Contents

General information

Characteristic maps

Advantages

Technical data

Documentation and tests

Spare parts

Connections

Collective measurements

Monitoring equipment

Options and accessories

Contact



Materials

VDMA No.	Parts designation	Material design S1 Pressure rating PN 25	Material design A8 Pressure rating PN 16
Parts coming into contact with conveying fluid			
102	Volute casing	1.0619+N	1.4408
230	Impeller	JL 1040	1.4408
230	Auxiliary impeller ⁽¹⁾	1.4581	1.4581
360	Bearing cover	1.0460	1.4571
381	Bearing support	1.0570	1.4571
400	Gasket	AFM34 or Gylon ⁽⁴⁾	AFM34 or Gylon ⁽⁴⁾
400	Spiral gasket	1.4404 / graphite	1.4404 / graphite
472	Slide ring	PTFE / K ⁽⁵⁾	PTFE / K ⁽⁵⁾
513	Wear ring insert	JL 1040	1.4571
529	Bearing sleeve	1.4571 / W5 ⁽²⁾	1.4571 / W5 ⁽²⁾
545	Bearing bush	1.4571 / SiC30 ⁽⁶⁾	1.4571 / SiC30 ⁽⁶⁾
816	Stator liner	2.4610	2.4610
819	Motor shaft	1.4021 / 1.4571	1.4571
Parts that do not come into contact with conveying liquid			
811	Motor casing	C-steel ⁽³⁾	C-steel ⁽³⁾
812	Motor casing cover	1.4571	1.4571

(1) parts only for CNF

(2) tungsten carbide coating

(3) material number depends on motor size

(4) For liquid temperatures > 120 °C: CrNi / Sigraflex HD

(5) For liquid temperatures > 120 °C: FH42A

(6) For liquid temperatures > 120 °C: 1.4462 / SiC-30

Contents

General information

Characteristic maps

Advantages

Technical data

Documentation
and tests

Spare parts

Connections

Collective measurements

Monitoring equipment

Options and accessories

Contact



Pressure and temperature limits

Material design S1 and A8

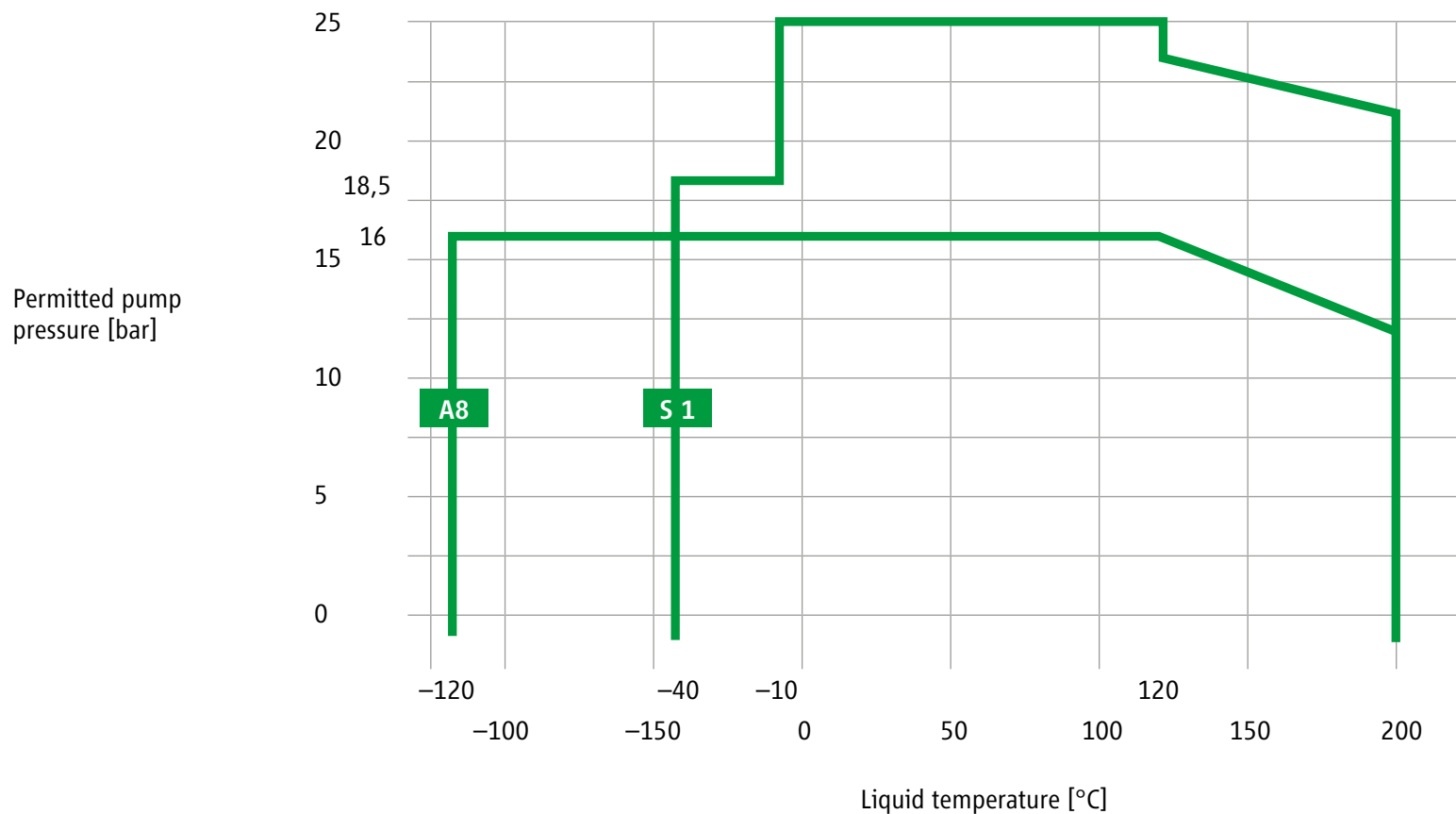

- Contents
- General information
- Characteristic maps
- Advantages
- Technical data**
- Documentation and tests
- Spare parts
- Connections
- Collective measurements
- Monitoring equipment
- Options and accessories
- Contact



Canned motors with H-winding

Canned motor data

Output power P2:	max. 41 kW (50 Hz) / max. 48 kW (60 Hz)
Voltage (±10 %) / frequency / circuit:	400V / 50 Hz / delta 480V / 60 Hz / delta 500V / 50 Hz / delta 600V / 60 Hz / delta 690V / 50 Hz / star (all canned motors are suitable for inverter operation)
Insulation class:	H-180
Operating mode:	S1 according to EN 60034-1
Protection class:	IP 67 (stator), IP 55 (terminal box)
Motor protection in winding:	Thermistor KL180 (standard), PT100 (option)
Rotation monitoring:	ROMi

Explosion protection according to Directive 2014 / 34 / EU

Incl. EC type-examination certificate

Marking:  II 2 G Ex de IIC T3 to T6

Noise expectancy values

Motors	N24N-2	N34L-2	N34XL-2	N54XL-2	N64XL-2
Output power [P2 at 50 Hz]	6,0 kW	8.0 kW	14.8 kW	24.0 kW	41.0 kW
max. expected sound pressure level dB(A) at 50 Hz	55	57	59	61	64
Output power [P2 at 60 Hz]	7,2 kW	10.5 kW	17.2 kW	27.0 kW	48.0 kW
max. expected sound pressure level dB(A) at 60 Hz	56	58	60	62	64

Contents

General information

Characteristic maps

Advantages

Technical data

Documentation
and tests

Spare parts

Connections

Collective measurements

Monitoring equipment

Options and accessories

Contact



Canned motors with C-winding

Canned motor data

Output power P2:	max. 33 kW (50 Hz) / max. 8,5 kW (60 Hz)
Voltage (±10 %) / frequency / circuit:	400V / 50 Hz / delta 480V / 60 Hz / delta 500V / 50 Hz / delta 600V / 60 Hz / delta 690V / 50 Hz / star (all canned motors are suitable for inverter operation)
Insulation class:	C-220
Operating mode:	S1 according to EN 60034-1
Protection class:	IP 67 (stator), IP 55 (terminal box)
Motor protection in winding:	3 x PT100
Rotation monitoring:	ROMi

Explosion protection according to Directive 2014 / 34 / EU

Incl. EC type-examination certificate

Marking:  II 2 G Ex de IIC T3 to T6

Noise expectancy values

Motors	T34L-2 C2	T54p-2 RC2	T64r-2 RC2	T74n-2 C2
Output power [P2 at 50 Hz]	7,1 kW	8,4 kW	13,5 kW	33 kW
max. expected sound pressure level dB(A) at 50 Hz	56	56	59	63
Output power [P2 at 60 Hz]	8,5 kW			
max. expected sound pressure level dB(A) at 60 Hz	56			

Contents

General information

Characteristic maps

Advantages

Technical data

Documentation
and tests

Spare parts

Connections

Collective measurements

Monitoring equipment

Options and accessories

Contact



Forces and torques

The pumps are designed so that they can absorb forces and torques according to ISO 5199.

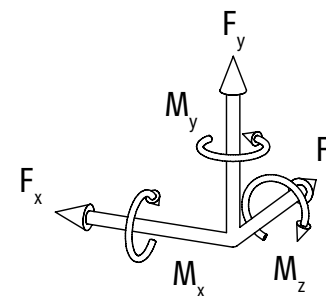
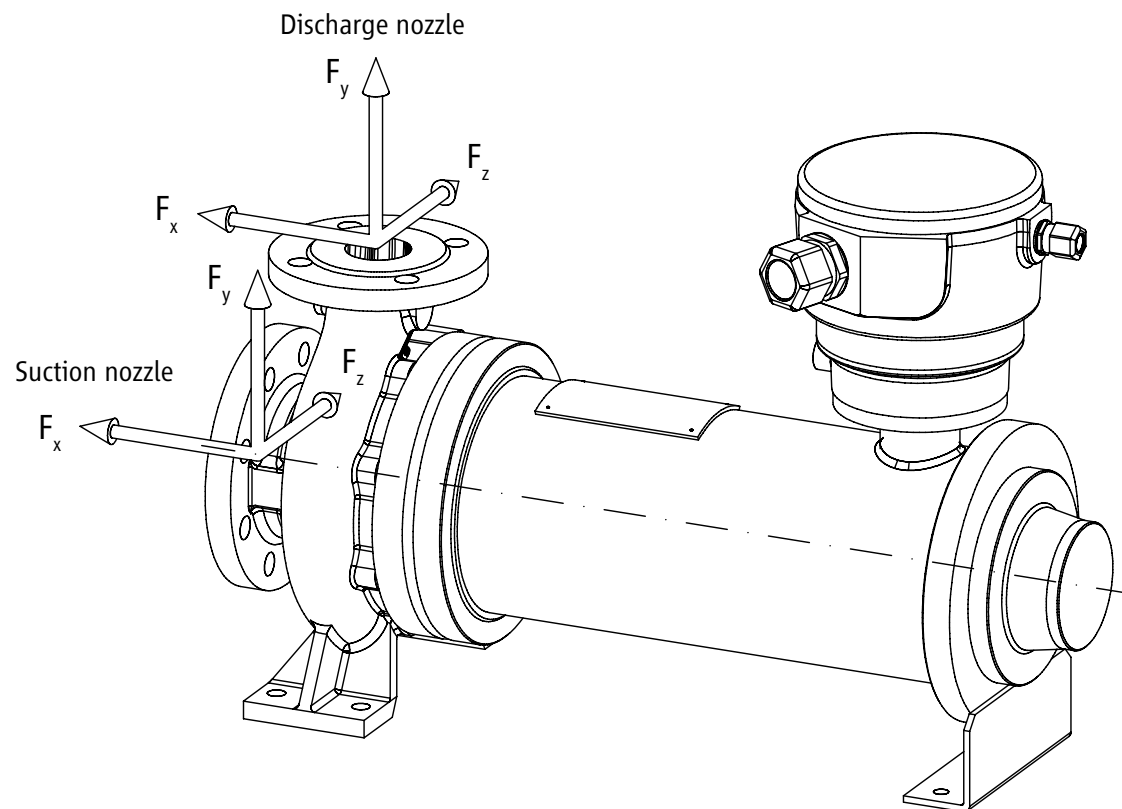

Contents

General information

Characteristic maps

Advantages

Technical data

Documentation and tests

Spare parts

Connections

Collective measurements

Monitoring equipment

Options and accessories

Contact



Permitted forces and torques on the pump nozzles (installation with base plate and firm foundation)

Material design S1 Material design A8

Sizes	Forces						Torques					
	Suction nozzle in N			Discharge nozzle in N			Suction nozzle in Nm			Discharge nozzle in Nm		
	F _x	F _y	F _z	F _x	F _y	F _z	M _x	M _y	M _z	M _x	M _y	M _z
40-25-200	1050 S1	700 S1	850 S1	500 S1	350 S1	450 S1	550 S1	450 S1	300 S1	400 S1	300 S1	200 S1
	900 A8	600 A8	750 A8	900 A8	300 A8	400 A8	500 A8	400 A8	250 A8	350 A8	250 A8	150 A8
50-32-200	1350 S1	900 S1	1100 S1	700 S1	450 S1	550 S1	700 S1	550 S1	350 S1	450 S1	350 S1	250 S1
	1150 A8	800 A8	950 A8	600 A8	350 A8	500 A8	650 A8	500 A8	300 A8	400 A8	300 A8	200 A8
50-32-250	1350 S1	900 S1	1100 S1	700 S1	450 S1	550 S1	700 S1	550 S1	350 S1	450 S1	350 S1	250 S1
	1150 A8	800 A8	950 A8	600 A8	350 A8	500 A8	650 A8	500 A8	300 A8	400 A8	300 A8	200 A8
65-40-160	1750 S1	1150 S1	1400 S1	850 S1	550 S1	700 S1	1150 S1	850 S1	600 S1	550 S1	450 S1	300 S1
65-40-200												
65-40-250												
80-50-160	2150 S1	1400 S1	1700 S1	1100 S1	700 S1	900 S1	1450 S1	1100 S1	750 S1	700 S1	550 S1	350 S1
80-50-200												
80-50-250												
100-65-200	2700 S1	1750 S1	2150 S1	1400 S1	900 S1	1150 S1	2000 S1	1500 S1	1000 S1	1150 S1	850 S1	600 S1
100-65-250	2300 A8	1500 A8	1850 A8	1200 A8	750 A8	1000 A8	1750 A8	1300 A8	900 A8	1000 A8	750 A8	500 A8

The specifications for the forces and torques only apply for static piping.

The specifications apply for installation with completely encapsulated base plate screwed on a rigid even foundation.

- Contents
- General information
- Characteristic maps
- Advantages
- Technical data
- Documentation and tests
- Spare parts
- Connections
- Collective measurements
- Monitoring equipment
- Options and accessories
- Contact



Documentation and tests

Documentation according to HERMETIC Standard, consisting of:

Operating manual for the HERMETIC pump

Technical specifications

Sectional and assembly drawings

Dimensional drawing

Cable connection diagram

Pump characteristic curve design

Acceptance report and pump characteristic curve

Electric test report

Slip ring report / gap size report, slide bearing clearancies

Factory certificates according to DIN EN 10 204 / 2.2

EC type-examination certificate PTB 99 ATEX

EU Declaration of Conformity

TÜV certificates

Optional documentation

Customized drawing

Customized parts list layout

Customer acceptance test at HERMETIC Headquarter

Schedule (status production planning) (available monthly or weekly)

Coating according to HERMETIC Standard

Temperature < 120 °C

Thickness: 100–200 µm (primer, then 2 coats)

Colour: RAL 7030 (stone grey)

Base plate: powder-coated

Temperature > 120 °C

Thickness: 100–200 µm (primer, then 2 coats)

Colour: Aluminium (similar to RAL 9006)

Base plate: powder-coated

Standard tests

Hydrostatic pressure test with 1.5x nominal pressure

Factory certificates according to DIN EN 10 204 / 2.2

Test run according to DIN EN ISO9906, Class 2 B (5 measuring points)

Balancing of the shaft and impeller according to DIN ISO 1940, 6.3 [without report]

Axial thrust measurement

Leak test for the complete pump with N₂ at 6 bar

Optional test

NPSH-test

Contents

General information

Characteristic maps

Advantages

Technical data

Documentation and tests

Spare parts

Connections

Collective measurements

Monitoring equipment

Options and accessories

Contact



Reduced part list

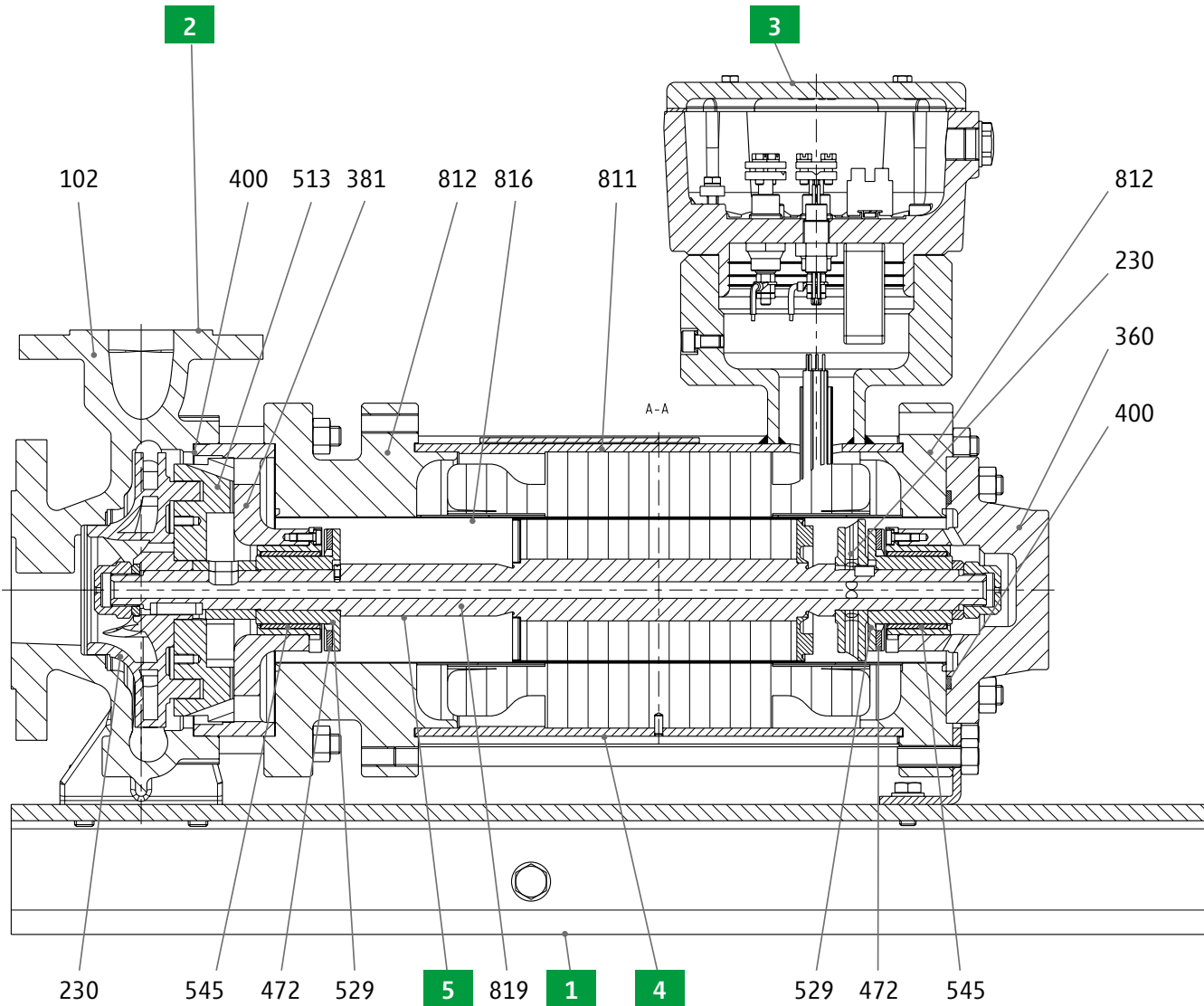

Number	Assembly drawing
1	Base plate
2	Hydraulics
3	Terminal box
4	Motor
5	Motor shaft

- Contents
- General information
- Characteristic maps
- Advantages
- Technical data
- Documentation and tests
- Spare parts**
- Connections
- Collective measurements
- Monitoring equipment
- Options and accessories
- Contact



Reduced part list

VDMA Pos.	Name	Assembly	Assembly drawing
102	Volute casing	Hydraulics	2
513	Wear ring insert	Hydraulics	2
381	Bearing support	Hydraulics	2
545	Bearing bush	Hydraulics	2
400	Gasket	Hydraulics	2

400	Spiral gasket	Motor	4
816	Stator liner	Motor	4
812	Motor casing cover, front	Motor	4
812	Motor casing cover	Motor	4
811	Motor casing	Motor	4
360	Bearing cover	Motor	4
545	Bearing bush	Motor	4

Refer to the relevant assembly drawing for the full list of the complete parts. These form part of the standard documentation.

VDMA Pos.	Name	Assembly	Assembly drawing
819	Motor shaft	Motor shaft	5
230	Impeller	Motor shaft	5
529	Bearing sleeve	Motor shaft	5
230	Auxiliary impeller (*)	Motor shaft	5
472	Slide ring	Motor shaft	5

(*) only CNF

Recommended spare parts stock

For overhaul: **for each pump**

4 pcs. Pos. 400 gasket
 2 pcs. Pos. 400 spiral gasket
 2 pcs. Pos. 529 bearing sleeve
 2 pcs. Pos. 545 bearing bush
 2 pcs. Pos. 472 slide ring

Spare Parts

Spare part package 1

1 set of gaskets and spiral gaskets

Spare part package 2

1 bearing set (bearing sleeve and bearing bush)

After Sales Kit

Spare part package 1 and 2

Contents

General information

Characteristic maps

Advantages

Technical data

Documentation and tests

Spare parts

Connections

Collective measurements

Monitoring equipment

Options and accessories

Contact



Terminal box connections

Motor size	Terminal box size	Number and thread for cable gland		Clamping area for cable		Cable inlet connection		Connection cross-section for motor
		Motor	Monitoring	Motor	Monitoring	Motor	Monitoring Multiple feedthrough with 6 wires	
N24N-2	Size 44	1 x M25x1,5	1 x M20x1,5	Cable ø 13–18	Cable ø 6–13	3 x TOS4.16A.690 V	–	1,5–6,0 mm ²
N34L-2	Size 54	1 x M40x1,5	1 x M20x1,5	Cable ø 17–28	Cable ø 6–13	3 x PLD 6 (M20x1,5)	1x (M16x1)	max. 35 mm ²
T34L-2 C2	Size 54	1 x M40x1,5	1 x M20x1,5	Cable ø 17–28	Cable ø 6–13	3 x PLD 6 (M20x1,5)	1x (M16x1)	max. 35 mm ²
N34XL-2	Size 54	1 x M40x1,5	1 x M20x1,5	Cable ø 17–28	Cable ø 6–13	3 x PLD 6 (M20x1,5)	1x (M16x1)	max. 35 mm ²
N54XL-2	Size 54	1 x M40x1,5	1 x M20x1,5	Cable ø 17–28	Cable ø 6–13	3 x PLD 6 (M20x1,5)	1x (M16x1)	max. 35 mm ²
T54p-2 RC2	Size 54	1 x M40x1,5	1 x M20x1,5	Cable ø 17–28	Cable ø 6–13	3 x PLD 6 (M20x1,5)	1x (M16x1)	max. 35 mm ²
N64XL-2	Size 64	1 x M40x1,5	1 x M20x1,5	Cable ø 17–28	Cable ø 6–13	3 x PLD 8 (M26x1,5)	1x (M16x1)	16–50 mm ²
T64r-2 RC2	Size 54	1 x M40x1,5	1 x M20x1,5	Cable ø 17–28	Cable ø 6–13	3 x PLD 6 (M20x1,5)	1x (M16x1)	max. 35 mm ²
T74n-2 C2	Size 74	1 x M63x1,5	1 x M20x1,5	Cable ø 31–48	Cable ø 6–13	3 x PLD 10	1x (M16x1)	16–95 mm ²

Size 54

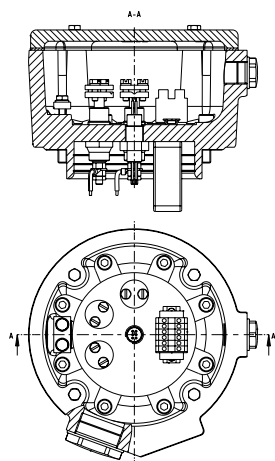

Size 64

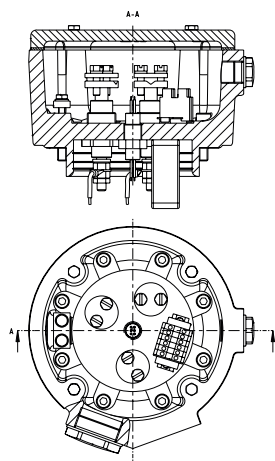

Size 74

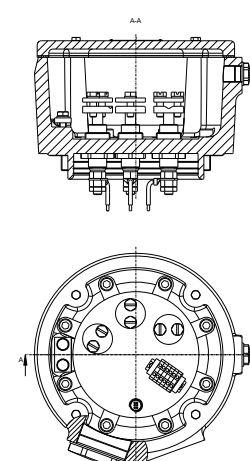

Contents

General information

Characteristic maps

Advantages

Technical data

Documentation and tests

Spare parts

Connections

Collective measurements

Monitoring equipment

Options and accessories

Contact



Collective measurement drawing

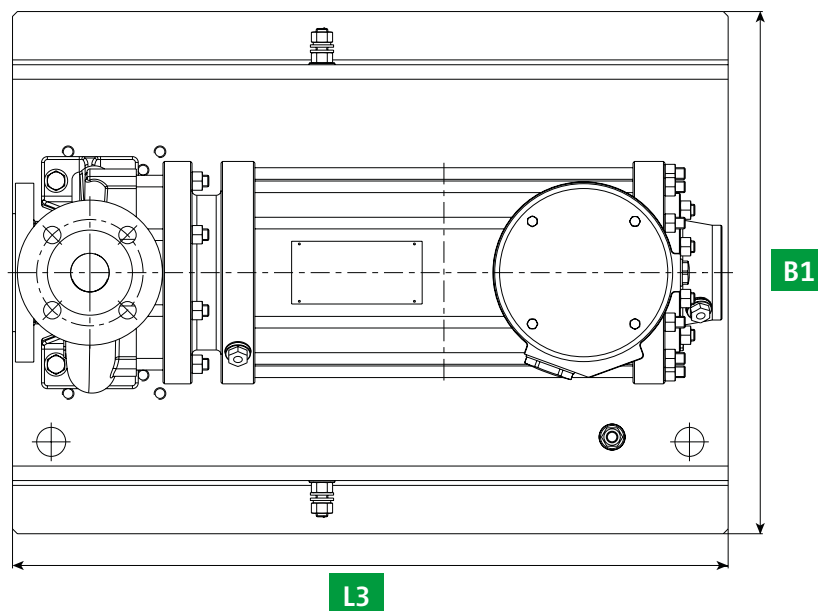
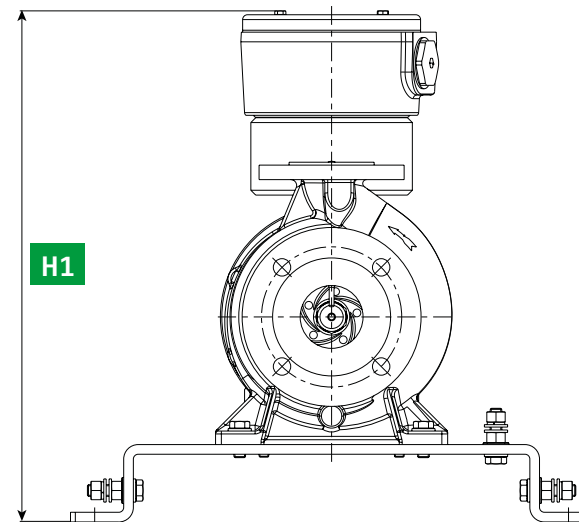
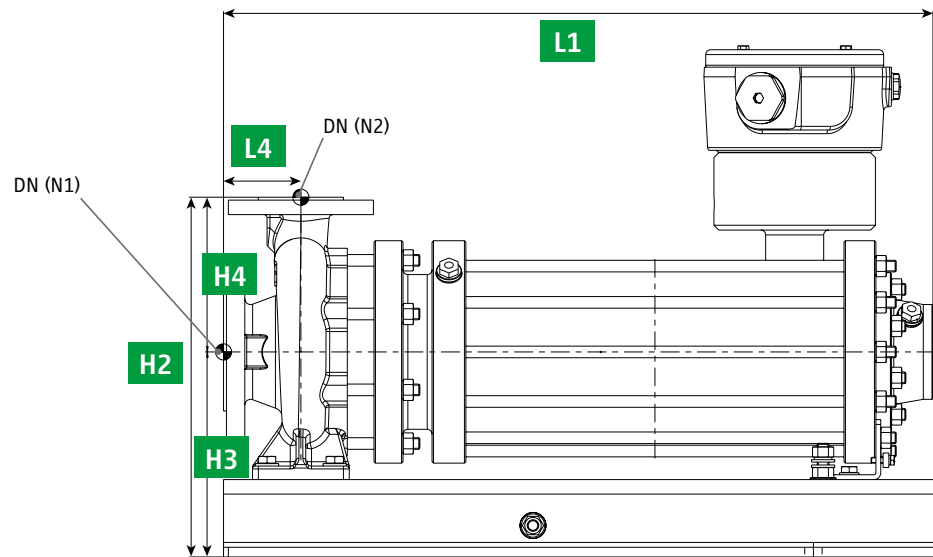

- Contents
- General information
- Characteristic maps
- Advantages
- Technical data
- Documentation and tests
- Spare parts
- Connections
- Collective measurements**
- Monitoring equipment
- Options and accessories
- Contact



Collective measurement data

Hydraulics	Motor	H1	L1	H2	H3	H4	L4	L3	B1	DN (N1)	DN (N2)	Total approx. weight in kg
50-32-200	N34L-2	557	639	420	240	180	80	740	540	50	32	190
65-40-160	N34L-2	529	639	372	212	160	80	740	540	65	40	140
65-40-160	N34XL-2	529	734	372	212	160	80	740	540	65	40	200
65-40-160	N54XL-2	563	839	392	232	160	80	900	540	65	40	275
65-40-200	N34L-2	557	659	420	240	180	100	740	540	65	40	200
65-40-200	N34XL-2	557	754	420	240	180	100	740	540	65	40	215
65-40-200	N54XL-2	571	859	420	240	180	100	900	540	65	40	300
65-40-250	N34XL-2	557	768	485	260	225	100	740	540	65	40	225
65-40-250	N54XL-2	571	873	485	260	225	100	900	540	65	40	300
65-40-250	N64XL-2	610	976	485	260	225	100	1000	540	65	40	425
80-50-160	N34L-2	557	659	420	240	180	100	740	540	80	50	200
80-50-160	N34XL-2	557	754	420	240	180	100	740	540	80	50	200
80-50-160	N54XL-2	571	859	420	240	180	100	900	540	80	50	275
80-50-200	N34L-2	557	659	440	240	200	100	740	540	80	50	200
80-50-200	N34XL-2	557	754	440	240	200	100	740	540	80	50	225
80-50-200	N54XL-2	571	859	440	240	200	100	900	540	80	50	300
80-50-200	N64XL-2	610	964	460	260	200	100	1000	540	80	50	375
80-50-250	N34XL-2	557	793	485	260	225	125	740	540	80	50	250
80-50-250	N54XL-2	571	898	485	260	225	125	900	540	80	50	325
80-50-250	N64XL-2	610	1001	485	260	225	125	1000	540	80	50	400
100-65-200	N34XL-2	577	765	485	260	225	100	740	540	100	65	225
100-65-200	N54XL-2	591	865	485	260	225	100	900	540	100	65	300
100-65-200	N64XL-2	630	970	485	260	225	100	1000	540	100	65	425
100-65-250	N54XL-2	591	898	530	280	250	125	900	540	100	65	325
100-65-250	N64XL-2	630	1001	530	280	250	125	1000	540	100	65	425

Contents

General information

Characteristic maps

Advantages

Technical data

Documentation
and tests

Spare parts

Connections

Collective measurements

Monitoring equipment

Options and accessories

Contact



Collective measurement data

Hydraulics	Motor	H1	L1	H2	H3	H4	L4	L3	B1	DN (N1)	DN (N2)	Total approx. weight in kg
40-25-200	N24N-2	545	580	420	240	180	80	740	540	40	25	170
50-32-160	N24N-2	517	580	372	212	160	80	740	540	50	32	150
40-25-200	N34L-2	553	639	420	240	180	80	740	540	40	25	190
50-32-160	N34L-2	525	639	372	212	160	80	740	540	50	32	175
50-32-160	T34L-2 C2	585	807	372	212	160	80	740	540	50	32	180
50-32-200	T34L-2 C2	614	807	420	240	180	80	740	540	50	32	195
65-40-160	T34L-2 C2	585	807	372	212	160	80	740	540	65	40	180
65-40-200	T34L-2 C2	614	827	420	240	180	80	740	540	65	40	195
80-50-160	T34L-2 C2	614	827	420	240	180	80	740	540	80	50	185
40-25-200	T54p-2 RC2	642	835	420	240	180	80	740	540	40	25	260
50-32-160	T54p-2 RC2	634	835	372	212	180	80	740	540	50	32	250
50-32-200	T54p-2 RC2	642	835	420	240	180	80	740	540	50	32	250
65-40-160	T54p-2 RC2	634	835	372	212	180	80	740	540	65	40	250
65-40-200	T54p-2 RC2	642	855	420	240	180	80	740	540	65	40	260
80-50-160	T54p-2 RC2	642	855	420	240	180	80	740	540	80	50	250
80-50-250	T54p-2 RC2	662	892	485	260	225	125	740	540	80	50	300
65-40-160	T64r-2 RC2	675	870	415	225	160	80	900	540	65	40	325
65-40-200	T64r-2 RC2	680	924	440	260	180	80	900	540	65	40	340
80-50-160	T64r-2 RC2	680	900	440	260	180	80	900	540	80	50	325
80-50-200	T64r-2 RC2	680	924	460	260	200	80	900	540	80	50	340
50-32-250	T74n-2 C2	756	1134	485	260	225	100	1000	540	50	32	450
65-40-250	T74n-2 C2	756	1134	485	260	225	100	1000	540	65	40	450
80-50-250	T74n-2 C2	756	1159	485	260	225	125	1000	540	80	50	450

Contents

General information

Characteristic maps

Advantages

Technical data

Documentation
and tests

Spare parts

Connections

Collective measurements

Monitoring equipment

Options and accessories

Contact



Over view of the safety- and function-related monitoring equipment

Level monitoring of the pumped liquid for detecting and avoiding dry running



Level monitoring by / with:

- KSR magnetic float switch [LS]
- Vibration limit switch [LS]
- Optoelectronic liquid level limit transducer [LS]

Temperature monitoring for detecting and avoiding inadmissible high temperatures in the pump and the motor



Temperature monitoring by / with:

- Resistance thermometer PT100 [TI]
- Thermistor KL180 [TS]

Rotor position monitoring for detecting and avoiding axial wear



Rotor position monitoring by / with:

- ACS [GI]

Rotation monitoring for detecting and avoiding incorrect phase sequence



Rotation monitoring by / with:

- ROMi [GS]

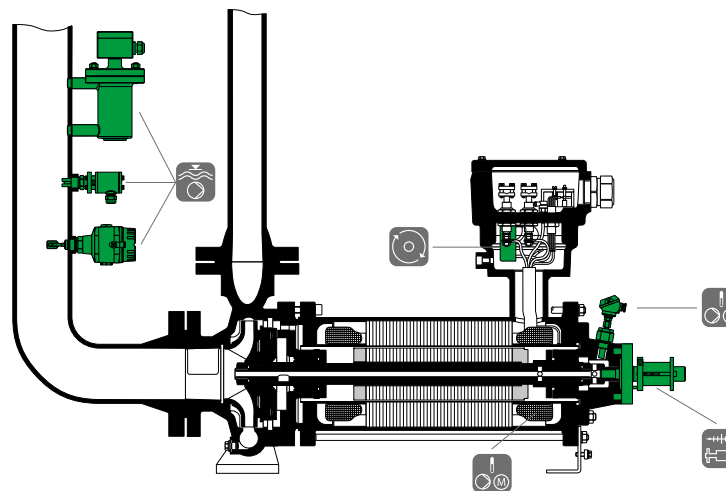

Example shown

Contents

General information

Characteristic maps

Advantages

Technical data

Documentation and tests

Spare parts

Connections

Collective measurements

Monitoring equipment

Options and accessories

Contact



Options and accessories

Options and accessories without delivery time extension

Gaskets	Gylon 3501 E
Flange designs	<ul style="list-style-type: none"> ■ Type D (with groove) ■ Drilled according to ANSI 150 lbs / 300 lbs
Drains	Drilled, closed with plugs
Without base plate	
Second name plate	Customized name plate
Schedule	Status production planning (monthly or weekly)
Customer acceptance test	1 week lead for planning

Optionen, with delivery time extension

Voltages	500V / 50Hz, 600V / 60Hz
Winding protection	Resistance thermometer PT100 instead of KL180 (switching amplifier on request)
Drain with flange	Arrangement right / left (EN1092-1, Form B1 / Form D, ANSI 150 / 300 lbs RF)
Inducer	
Rotor monitoring	
Bearing with modified clearance	For operating temperature up to $< -40^{\circ}\text{C}$
Special Painting	
Flushing connection on bearing cover	On bearing cover, DIN EN 1092-1, Form B1, Form D or acc. to ANSI
Customized parts list layout	
Customized drawing	
Impeller in stainless steel	

- Contents
- General information
- Characteristic maps
- Advantages
- Technical data
- Documentation and tests
- Spare parts
- Connections
- Collective measurements
- Monitoring equipment
- Options and accessories**
- Contact



Options and accessories

Accessories

Level monitoring	<ul style="list-style-type: none"> ■ KSR magnetic float switch ■ Vibration limit switch ■ Optoelectronic liquid level limit transducer
Temperature monitoring	Resistance thermometer PT100
Levelling disc with adjusting screws, Isoloc	
Q_{max} -orifice	
Connection for PT100	Included

- Contents
- General information
- Characteristic maps
- Advantages
- Technical data
- Documentation and tests
- Spare parts
- Connections
- Collective measurements
- Monitoring equipment
- Options and accessories**
- Contact



MODEL INFORMATION

Contact

sales-support@hermetic-pumpen.com

www.hermetic-pumpen.com

YouTube | LinkedIn | Expert tool

Contents

General information

Characteristic maps

Advantages

Technical data

Documentation
and tests

Spare parts

Connections

Collective measurements

Monitoring equipment

Options and accessories

Contact