

PRODUCT INFORMATION

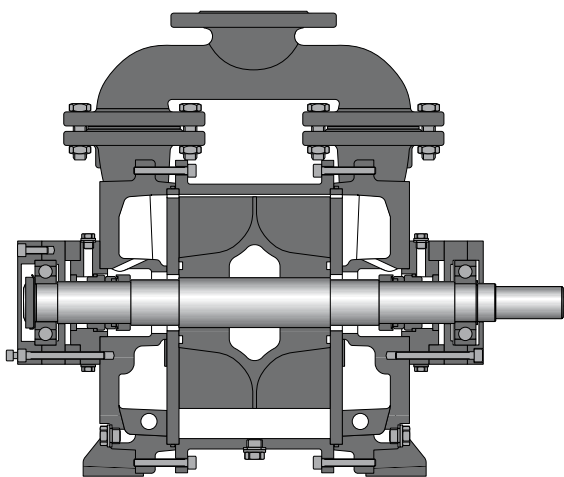

Liquid ring vacuum pumps  
Liquid ring compressors

Series LVP

## Contents

Description .....	2
Design .....	3
Application range .....	4
Material and performance range .....	5
Functional principle .....	6
Design options .....	7
Examples for vacuum systems .....	9
Performance curve .....	10

## Description

### General

LEDERLE-HERMETIC has been producing and successfully marketing both vacuum pumps and compressors to the whole world for decades. Operation, design and application have been constantly optimised and adapted to our customers' requirements. The pumps are available in conventional sealed and hermetically sealed units. Magnetic coupled or canned motor design guarantees operation without leakage and minimal maintenance. The compact design enables simple, fast and economical maintenance.

### Function

The vacuum pumps and compressors are rotary positive displacement pumps that cover a wide range of applications. The applications are in chemical, petrochemical, pharmaceutical, paint industries as well as general industries.

The internals of the liquid ring vacuum pump or compressor are partially filled with liquid in operation. Casing and port plates form the internals, where the eccentrically mounted rotating impeller forms a liquid ring. The liquid ring forms a cell between the impeller blades, that expands during rotation and thus draws the gas through the suction port. As the impeller rotates further, these cells are getting smaller and consequently compressing the gas through the discharge port. Together with the gas, a part of the liquid will be expelled through the discharge port that is separated from the gas in the separator.

By means of a flexible discharge port in the port plate, the liquid ring vacuum pump operates with maximum efficiency in the whole range of suction pressure. The port opening adapts to the actual compression ratio, so that overcompression will be avoided.

The major application of liquid ring vacuum pumps and compressors is in the handling of wet gas and vapours that will condense partially during compression. Because compression is near isothermal, these machines are specifically suitable for the handling of explosive or polymerising gases or vapours.

The liquid ring vacuum pumps can reach a maximum vacuum of about 30 mbar (abs). Lower suction pressures can be achieved in combination with gas or steam ejectors, or roots booster pumps.

# Design

Liquid ring vacuum pumps are positive displacement compressors, which are equipped with single or double suction impellers, according to size. Liquid ring vacuum pumps do not need lubricants; there are no parts in direct contact inside the hydraulics. Therefore these pumps feature low noise operation as well as simple and robust design.

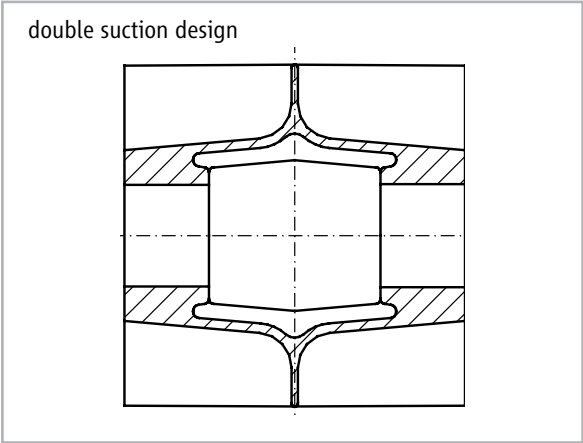
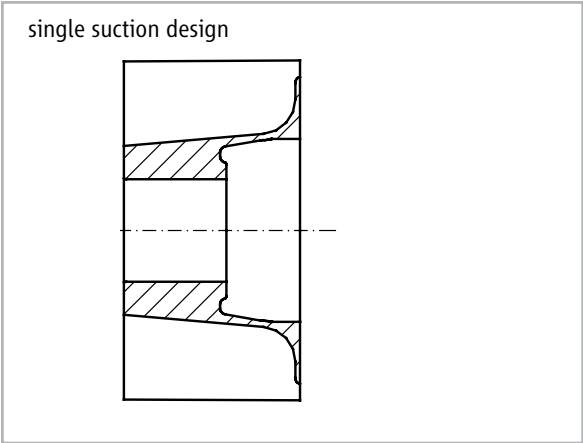

## Application range

---

### **Capacity**

Suction capacity is depending on rotational speed. Pump capacities up to 3000 m<sup>3</sup>/h are available.

### **Temperature**

Depending on the liquid and materials of construction a maximum liquid operating temperature of 100 °C is possible. Special designs for higher temperatures are available on request.

### **Pressure**

Depending on the design, liquid ring vacuum pumps are available for suction pressures down to approx. 30 mbar (abs) and discharge pressures up to 2500 mbar (abs), in special applications up to 6 bar possible.

### **Connections**

Nominal size is related to pump size. The range is for DN 40 to DN 100. Special executions, e.g. dimensions according to ANSI are available on request.

### **Shaft sealing**

All sizes of the LVP range can be equipped with various methods of shaft sealing. Available are single mechanical seals and double mechanical seals as well as hermetically sealed magnetic couplings and canned motors.

In hermetically sealed pumps, the shaft seal is replaced by a magnetic coupling or a canned motor. Therefore wear at seals is eliminated. The permanent magnetic coupling or canned motor transmits the torque between driver and pump through the containment shell and thus eliminates the shaft seal.

### **Environmental safety**

Liquid ring vacuum pumps and compressors are suitable for use on hazardous gases. Certifications for mechanical explosion protection according to European standard 94/9/EC (ATEX) Ⓢ II 2 G c T4 to T6 are available. Certification for Category 1 is also available. The pump seals are also certified by TÜV Cert to comply with "TA-Luft".

### **Quality**

HERMETIC liquid ring vacuum pumps and compressors are state of the art and quality is compliant to design standards e.g. ISO, VDMA, DIN and European standards. Our quality manual according to ISO 9001 supports the manufacturing process.

## Material and performance range

Parts	Steel / Cast steel	Stainless steel	Hastelloy	Titanium
End shield	GS-C25 1.0619	CrNiSt 1.4408	Hastelloy	Titanium
Port plate	St 52-3 1.0570	CrNiSt 1.4571	Hastelloy	Titanium
Casing	GS-C25 1.0619	CrNiSt 1.4408	Hastelloy	Titanium
Impeller	GS-C25 1.0619	CrNiSt 1.4408	Hastelloy	Titanium
Shaft	St 52-3 1.0570	CrNiSt 1.4571 / 1.4462	Hastelloy	Titanium
Bearing bracket	GGG 40	GGG 40	GGG 40	GGG 40
Mechanical seal	CrNiSt / Carbon / Viton	CrNiSt / Carbon / Viton	acc. to specification	acc. to specification
Magnetic coupling	CrNiSt / Hastelloy	CrNiSt / Hastelloy	Hastelloy	Titanium
Gaskets	AFM 34	AFM 34	acc. to specification	acc. to specification
O-rings	FEP / Viton	FEP / Viton	acc. to specification	acc. to specification
Slide bearings	SIC, CD6N / SIC30	SIC, CD6N / SIC30	SIC, CD6N / SIC30	SIC, CD6N / SIC30

### Performance range

Suction capacity [m <sup>3</sup> /h]:	up to 3000
Discharge pressure [mbar (abs)]:	up to 2500*
Temperature [°C]:	-20 to +100*
Pressure rating [PN]:	10*
Test pressure [bar]:	16*

\* Special design and operating conditions allow higher temperatures and pressures (consult factory).

### Sizes

Mechanical seal execution			Magnetic-coupled execution		Canned motor execution	
LVPS	LVPL	LVPG	LVPM		LVPH	
125	125	600	50	600	50	600
150	150	800	125	800	125	800
250	250	1200	150	1200	150	1200
	320	1800	250	1800	250	1800
	450	2200	320	2200	320	
		3000	450	3000	450	

### Pump and hydraulic denomination

LVP / M / 320 / \_

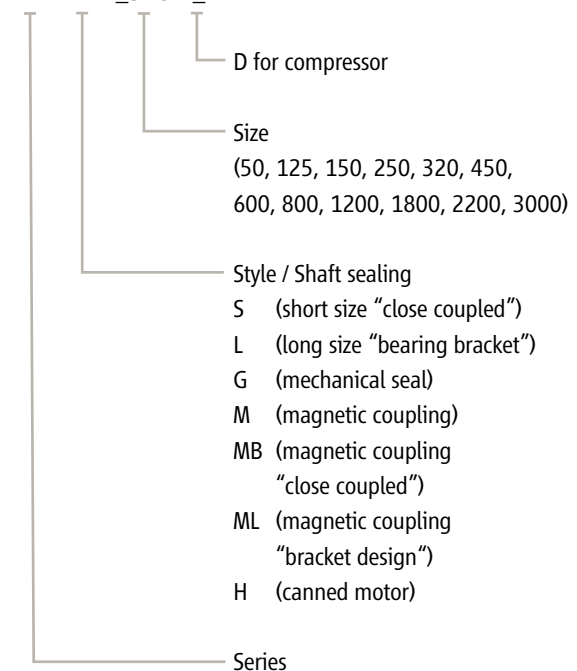

# Functional principle

LVPG

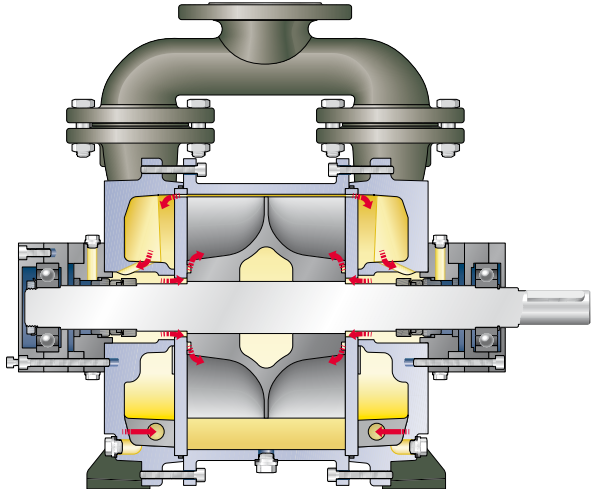

LVPM

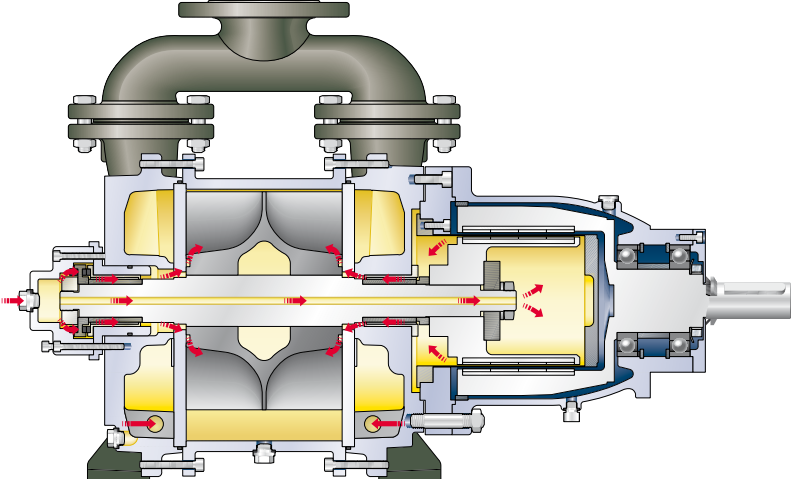

LVPMB

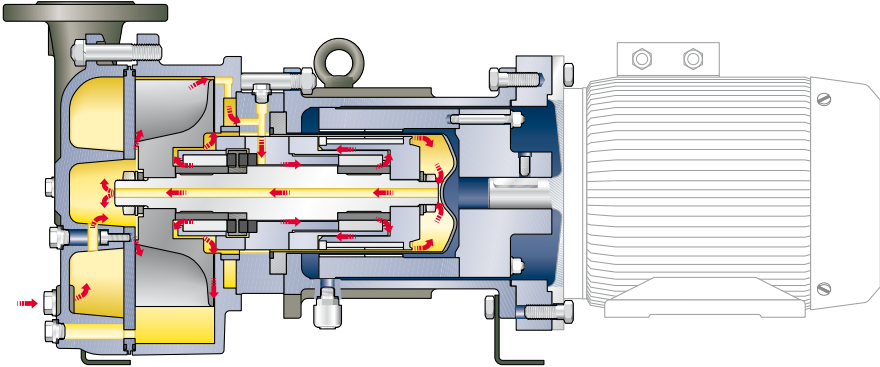

## Design options

---

### *with mechanical seal*

#### **LVPG**

Vacuum pump with single mechanical seal, external roller bearings and double suction impeller.

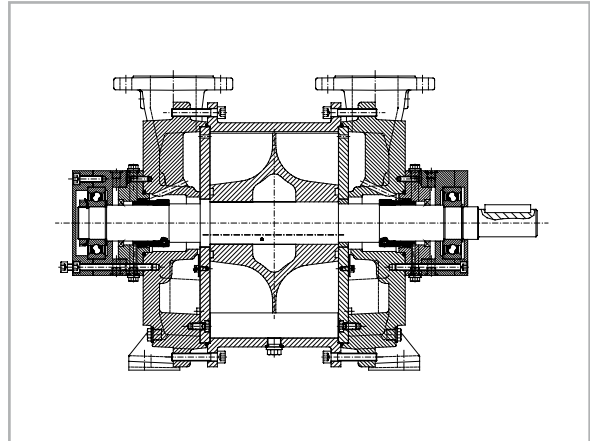

#### **LVPS**

Vacuum pump in short shaft size design, with single mechanical seal and single ended impeller with seat on motor shaft.

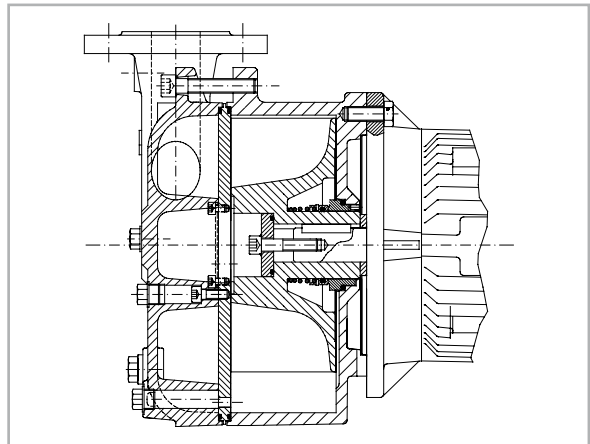

#### **LVPL**

Vacuum pump in bearing bracket design (long shaft size), with single mechanical seal and single ended impeller.

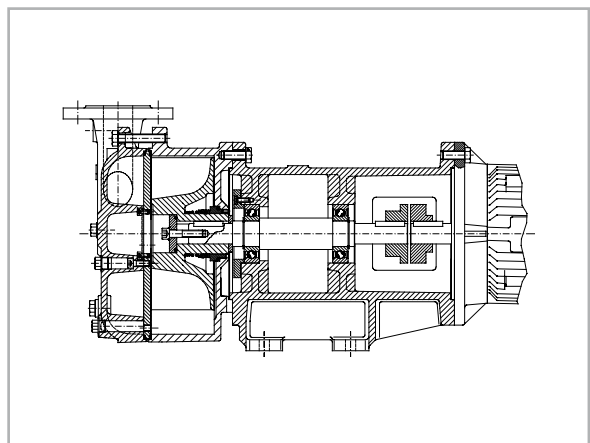

## Design options

### *with magnetic coupling*

#### **LVPM**

Vacuum pump with magnetic coupling, product lubricated slide bearings and double ended impeller.

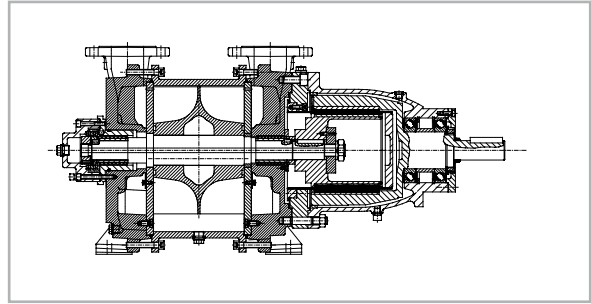

#### **LVPML**

Vacuum pump in bearing bracket design with magnetic coupling, product lubricated slide bearings and single ended impeller.

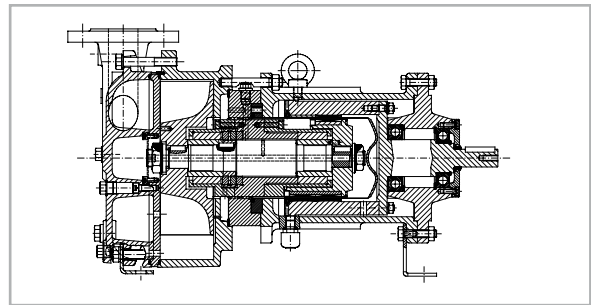

#### **LVPMB**

Vacuum pump in modular construction with magnetic coupling, product lubricated slide bearings and single ended impeller.

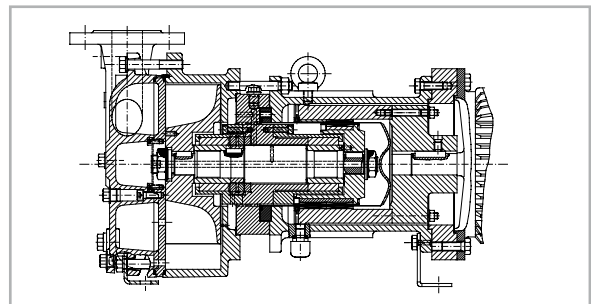

### *with canned motor*

#### **LVPH**

Vacuum pump with canned motor and product lubricated slide bearings and double ended impeller.

Special feature: flanged auxiliary pump

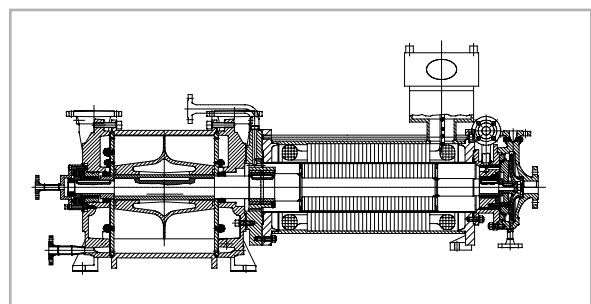

#### **LVPH**

Vacuum pump with canned motor and product lubricated slide bearings and single ended impeller.

Special feature: flanged auxiliary pump

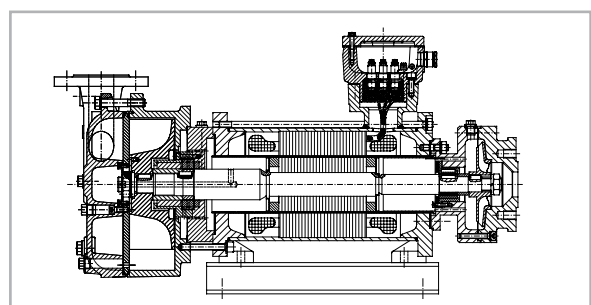



## Examples for vacuum systems

### Vacuum package unit type ALVPM 800

Liquid ring vacuum pump type LVPM 800  
(with magnetic coupling, double-flow)

- For suction of a mixture of:  
air, nitrogen, epichlorohydrin and water vapour
- Suction temperature approx. 20 °C
- Pumping capacity 280 m<sup>3</sup>/h at 26 mbar
- Compression to 1113 mbar

Special features: vacuum package unit with  
connected gas ejector



### Vacuum package unit type ALVPMB 150

Liquid ring vacuum pump type LVPMB 150  
(with magnetic coupling, close coupled, single-flow)

- For suction of a mixture of:  
air, nitrogen, epichlorohydrin and water vapour
- Suction temperature approx. 25 °C
- Pumping capacity 81 m<sup>3</sup>/h at 106 mbar
- Compression to 1113 mbar



### Vacuum package unit type ALBPH 1800

Liquid ring vacuum pump type LVPH 1800  
(with canned motor, double-flow)

- For suction of nitrogen
- Suction temperature approx. 40 to 45 °C
- Pumping capacity 1007 m<sup>3</sup>/h at 30 mbar
- Compression to 1113 to 1120 mbar

Special features: vacuum package unit with  
integrated canned motor pump type CNK and  
2 metering pumps



# Performance curve

50 Hz

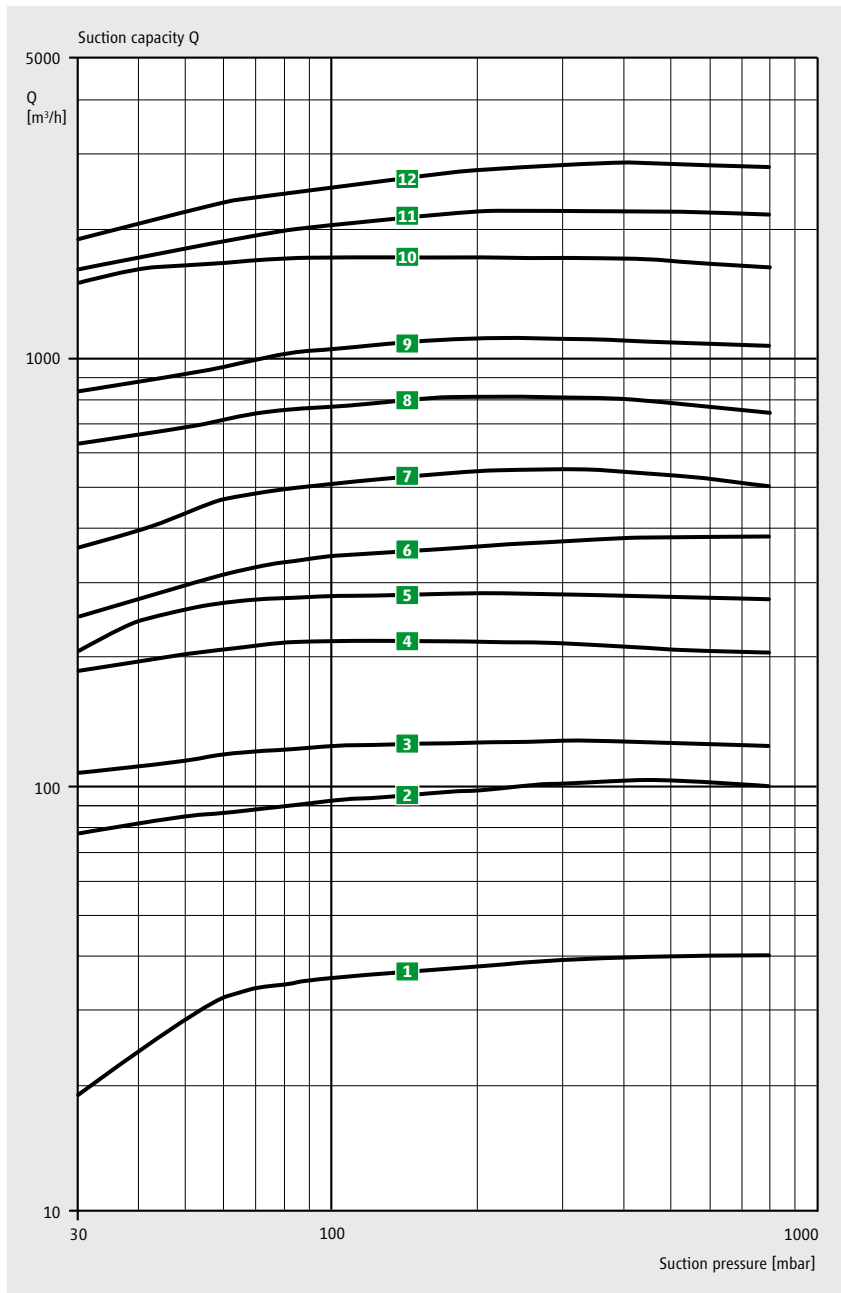

## Denomination to the performance curve

- 1** LVP 50/2850 min<sup>-1</sup>
- 2** LVP 125/1450 min<sup>-1</sup>
- 3** LVP 150/1450 min<sup>-1</sup>
- 4** LVP 250/1450 min<sup>-1</sup>
- 5** LVP 320/1450 min<sup>-1</sup>
- 6** LVP 450/1450 min<sup>-1</sup>
- 7** LVP 600/1450 min<sup>-1</sup>
- 8** LVP 800/1450 min<sup>-1</sup>
- 9** LVP 1200/970 min<sup>-1</sup>
- 10** LVP 1800/970 min<sup>-1</sup>
- 11** LVP 2200/740 min<sup>-1</sup>
- 12** LVP 3000/740 min<sup>-1</sup>

## 60 Hz

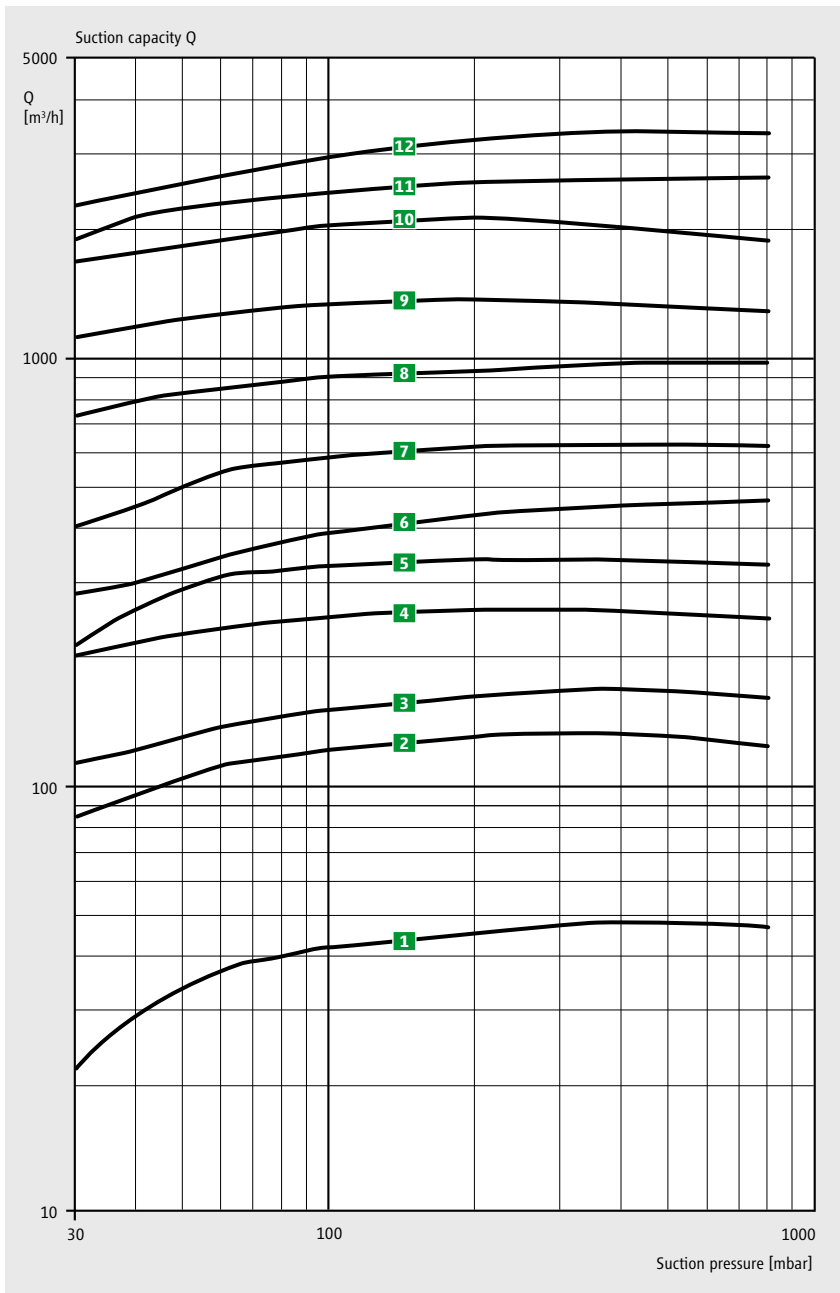

### Denomination to the performance curve

- 1 LVP 50/3420 min<sup>-1</sup>
- 2 LVP 125/1750 min<sup>-1</sup>
- 3 LVP 150/1750 min<sup>-1</sup>
- 4 LVP 250/1750 min<sup>-1</sup>
- 5 LVP 320/1750 min<sup>-1</sup>
- 6 LVP 450/1750 min<sup>-1</sup>
- 7 LVP 600/1750 min<sup>-1</sup>
- 8 LVP 800/1750 min<sup>-1</sup>
- 9 LVP 1200/1170 min<sup>-1</sup>
- 10 LVP 1800/1170 min<sup>-1</sup>
- 11 LVP 2200/880 min<sup>-1</sup>
- 12 LVP 3000/880 min<sup>-1</sup>

## Convincing service.

Important features are readiness, mobility, flexibility, availability and reliability. We are anxious to ensure a pump operation at best availability and efficiency to our customers.

### *Installation and commissioning*

- service effected on site by own service technicians

### *Spare part servicing*

- prompt and longstanding availability
- customized assistance in spare part stockkeeping

### *Repair and overhauling*

- professional repairs including test run executed by the parent factory
- or executed by one of our service stations worldwide

### *Retrofit*

- retrofit of your centrifugal pumps by installing a canned motor to comply with the requirements of the IPPC Directive

### *Maintenance and service agreement*

- concepts individually worked out to increase the availability of your production facilities

### *Training and workshops*

- extra qualification of your staff to ensure the course of your manufacture

### **Among others, our products comply with:**

- Directive 2006/42/EC (Machinery Directive)
- Explosion protection acc. to Directive 94/9/EC (ATEX); UL; KOSHA; NEPSI; CQST; CSA; Rostechnadzor
- Directive 96/61/EC (IPPC Directive)
- Directive 1999/13/EC (VOC Directive)
- TA-Luft
- RCC-M, Niveau 1, 2, 3

### **HERMETIC-Pumpen GmbH**

#### **is certified acc. to:**

- ISO 9001:2008
- GOST; GOST "R"
- Directive 94/9/EC
- AD 2000 HP 0; Directive 97/23/EC
- DIN EN ISO 3834-2
- KTA 1401; AVS D 100 / 50; IAEA 50-C-Q
- Certified company acc. to § 19 I WH

PRODUKTINFO  
LVP/E/04/2012

All details as stated in this document comply with the technical standard that is applicable at the date of printing. These details are subject to technical innovations and modifications at any time.



HERMETIC-Pumpen GmbH  
Gewerbestrasse 51 · D-79194 Gundelfingen  
phone +49 761 5830-0 · fax +49 761 5830-280  
vacuum@hermetic-pumpen.com  
www.hermetic-pumpen.com